



# NIS Activities in the Field of Electricity and Magnetism

**Assoc. Prof. Dr. Mohammed Helmy Abd El-Raouf**

Head of Electrical Quantities Metrology Department

National Institute of Standards (NIS), Egypt

Vice Chair of AFRIMETS TCEM

mohammed\_makka@yahoo.com,

mohammed\_makka@nis.sci.eg

# NIS Location

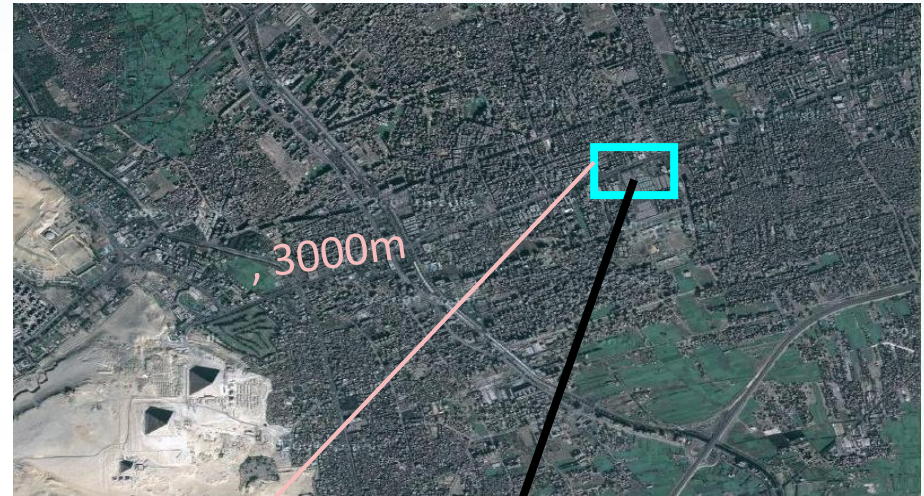



# NIS Timeline

Metrology begins in Egypt.  
The Royal Egyptian Cubit



2700BC

NIS moves to dedicated campus in Haram, Giza



1992

Twinning project with 5 European Union Laboratories

2016

NIS is Founded



1963



NIS signs Mutual Recognition Agreement

1999

2020



NIS intends to become the leading NMI serving the Arab World

## NIS Mission

- Establish, maintain and disseminate the SI units
- Research and develop new and improved measurement procedures.
- Provide calibration, training and consulting services.



# Links between NIS and National & International Organizations

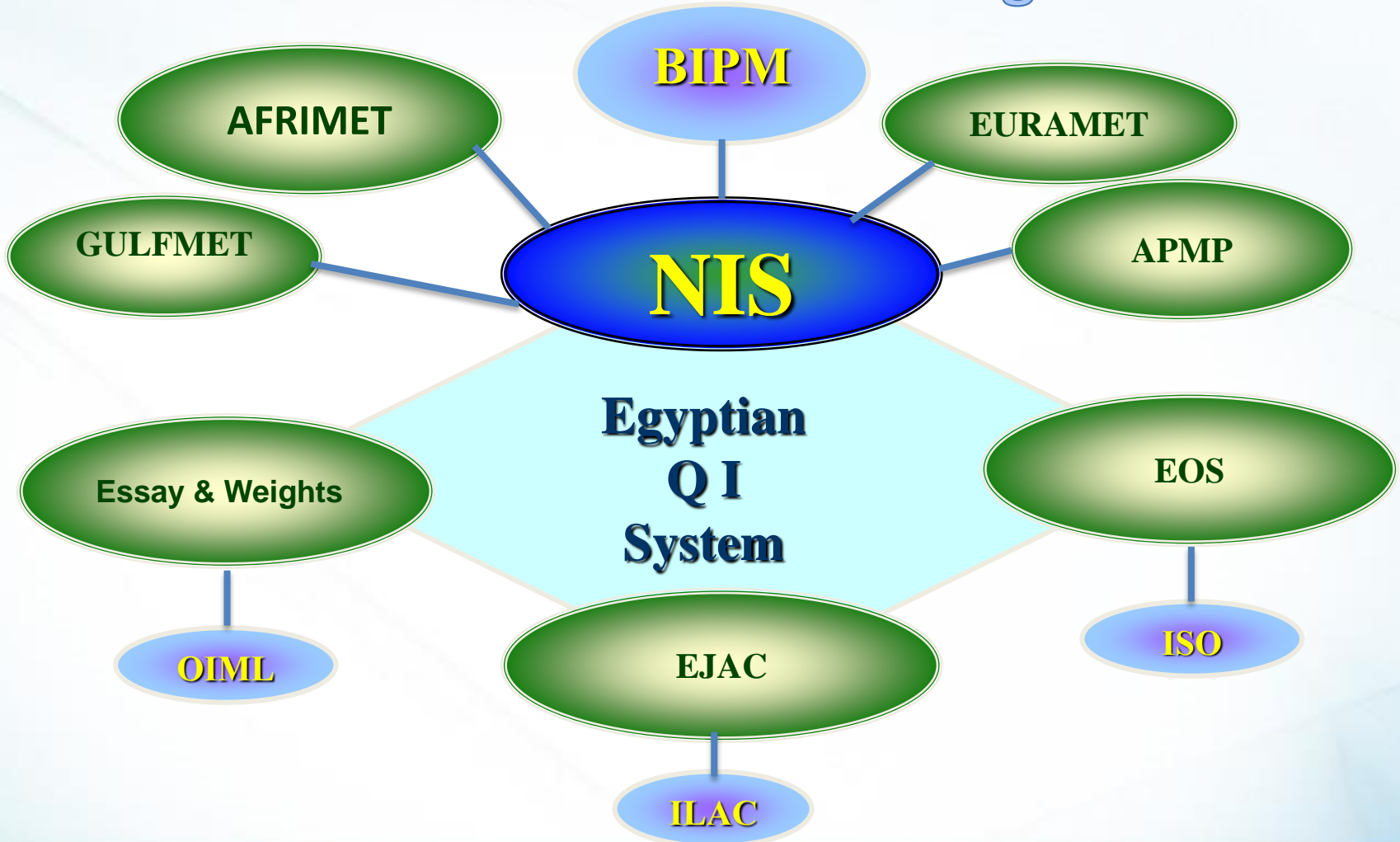



# NIS Services

Calibration & Testing

Quality System Consulting

Training Services

Proficiency Testing

Reference Materials



# NIS Customers

NIS serves clients  
in all major  
Industrial sectors  
and in many  
Government  
Organizations in  
Egypt and  
throughout the  
Arab and African  
World



The staff of NIS  
would be  
honored to  
serve YOU



# Ministry of Higher Education & Scientific Research

## Management Board

**NIS President**

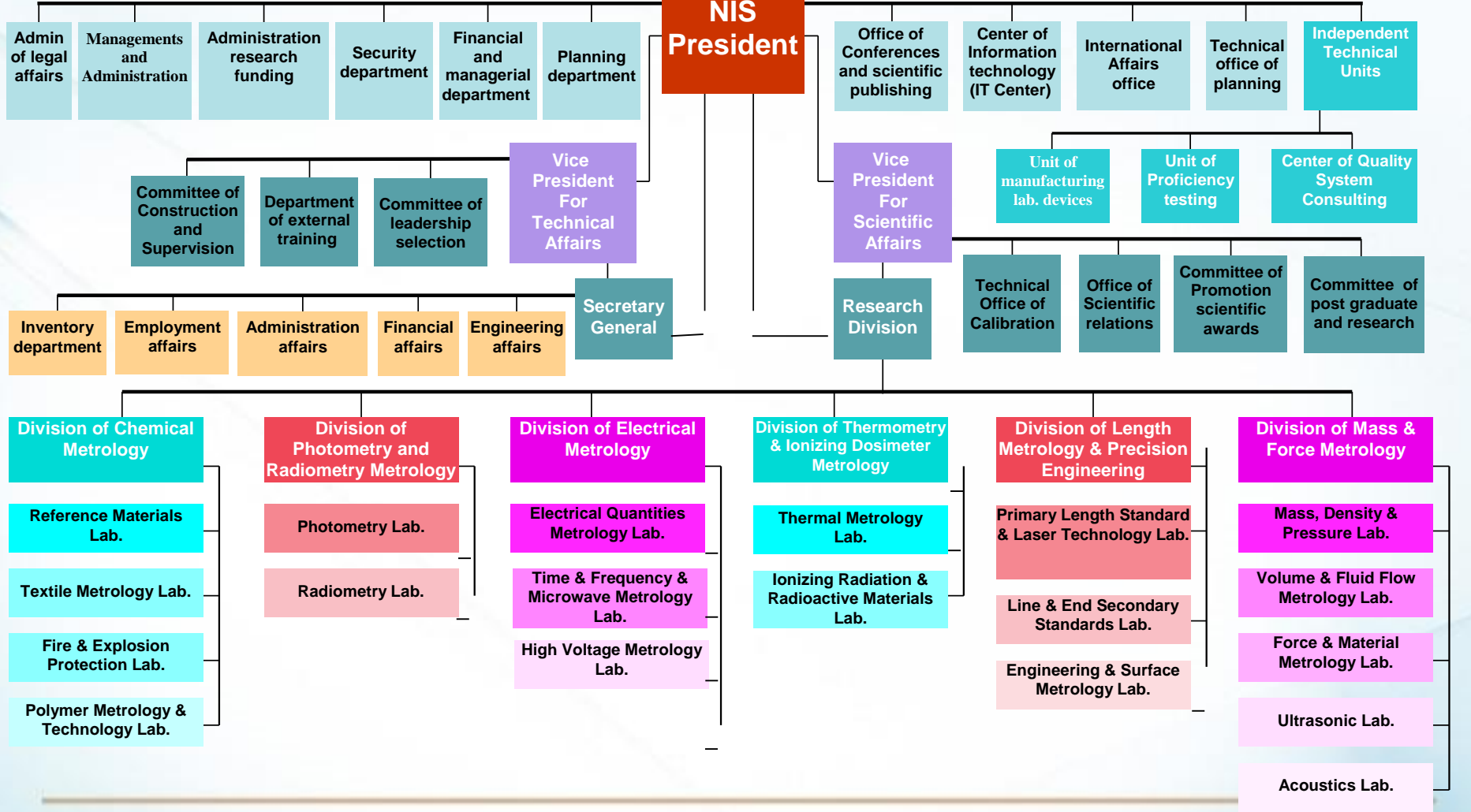

30th meeting of the CCEM,  
BIPM 22 and 24 March 2017

NIS Activities in the Field of Electricity and Magnetism





NIS has 6 scientific divisions with 21 laboratories.

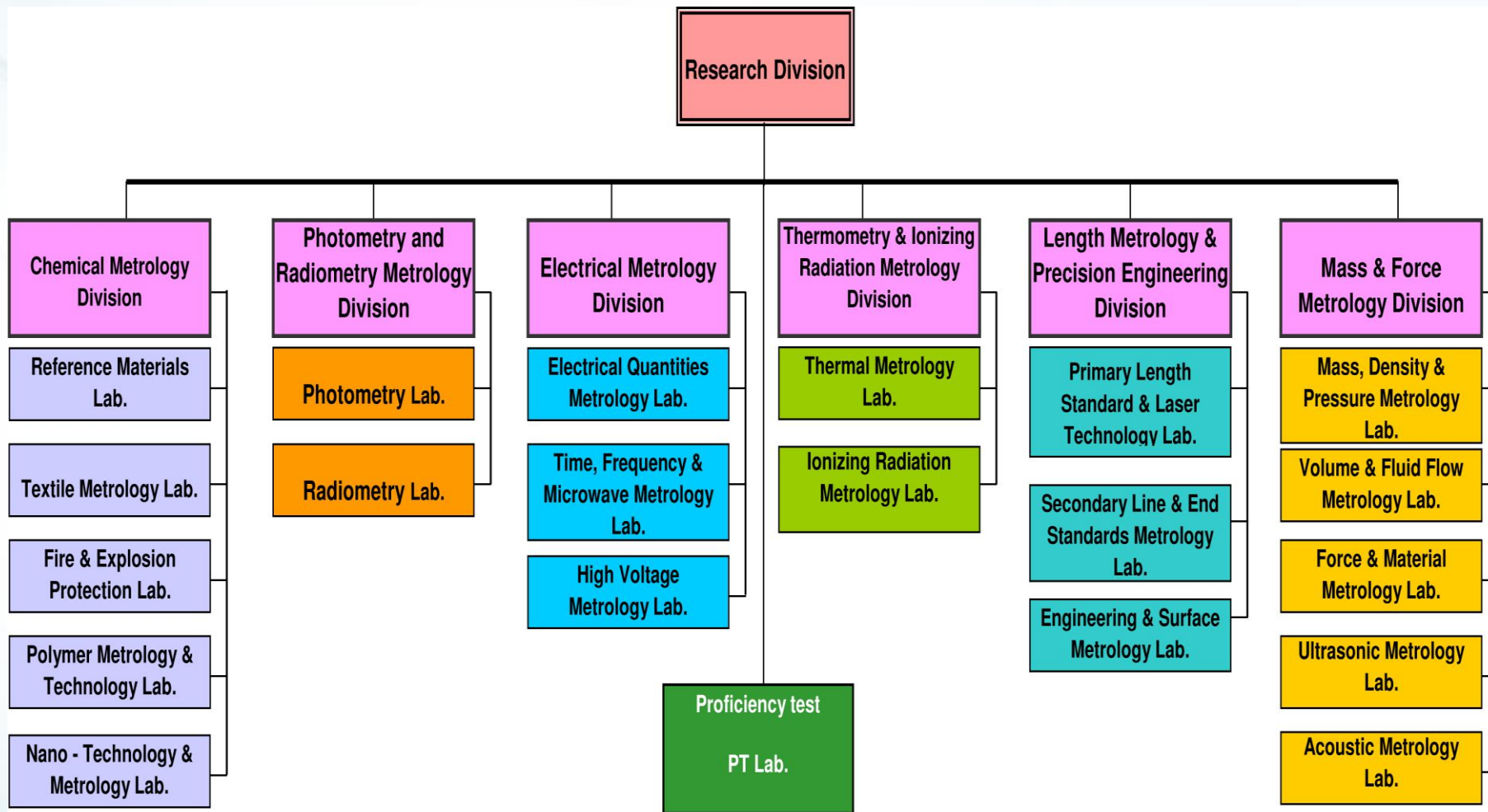



# NIS Capabilities in Electrical Quantities, High Voltage and Microwave Fields

# Electrical Quantities Metrology

## DC Voltage and Current

### Primary Standard

### Josephson Array Voltage Standard

Since 2009, the laboratory had the Josephson Array Voltage Standard (JAVS).

Range: -10 V to +10 V



# DC Voltage and Current

## Secondary Voltage Standard

The unit of voltage is maintained via 13 Zener diode reference standards as Secondary Standards with 10 V and 1.018 V outputs.



Zeners are Calibrated using JAVS.  
Exp. Uncer. =  $0.03 \mu\text{V}/\text{V}$  to  $0.2 \mu\text{V}/\text{V}$

## DC Voltage and Current

In 2014, NIS participated in BIPM.EM-K11.a and b. comparisons. The final report is already published ([Link](#))

### Comparison of 1.018 V and 10 V DC Voltage References

Quantity	Instrument or Artifact	Method of Measurement	Min. value	Max. value	Units	Value	Units	Coverage Factor	Level of Confidence
DC voltage sources: single values	DC solid state voltage standard	Direct Comparison with primary standard (JVS)	1.018	10	V	0.03 to 0.2	$\mu\text{V/V}$	2	95%

## DC Voltage and Current

NIS participated in EUROMET.EM-S24 comparison. The final report is already published ([Link](#))

### Comparison of ultra-low DC current sources

Quantity	Instrument or Artifact	Method of Measurement	Min. value	Max. value	Units	Value	Units	Coverage Factor	Level of Confidence
DC current sources: low values	Standard Capacitor , Voltage Source , High Resistance Standard	Current Generator: current generated by charging or discharging a gas-filled capacitor With Software Controlled for Nonlinearity Compensation	-1E-13	1E-10	A	0.03 to 0.2	$\mu\text{V/V}$	2	95%

## Resistance Standards



The unit of resistance is maintained by mean of five “One Ohm” Thomas type standard resistors traceable to the SI units by calibrating them periodically against the Quantum Hall resistance standards at the BIPM.

Exp. Uncer. =  $0.2 \mu\Omega/\Omega$

# Resistance Standards

There are also two 10 k $\Omega$  and two 100  $\Omega$  standard resistors, traceable to BIPM,

Exp. Uncer. (100  $\Omega$ ) = 0.3  $\mu\Omega/\Omega$

Exp. Uncer. (10 k $\Omega$ ) = 0.3  $\mu\Omega/\Omega$

Range from 100 k $\Omega$  to 100 M $\Omega$ .

Exp. Uncer. = 4  $\mu\Omega/\Omega$  : 761  $\mu\Omega/\Omega$





# Resistance Measurement



## Automated Resistance Bridge

Model 6010C is a fully automated resistance ratio bridge based on the Direct-Current-Comparator (DCC) principle.

Manufacturer Specifications:  
Range: 0.001 Ohm to 10 kOhm  
Accuracy: < 5 ppm to < 0.05 ppm

## Resistance Comparisons

NIS participated in EURAMET- EM-k2.1 comparison. The final report is already published ([Link](#)), and the related CMC's are also published at the BIPM data base ([Link](#))

### Comparison of Resistance Standards at 10 MΩ and 1 GΩ

Values: (100 kΩ to 1 MΩ) and (10 MΩ to 100 MΩ)

Quantity	Instrument or Artifact	Method of Measurement	Min. value	Max. value	Units	Value	Units	Coverage Factor	Level of Confidence
DC resistance standards and sources: high values	Fixed resistor	Potentiometric ratio bridge	1E+07	1E+08	Ω	94 to 760	μΩ/Ω	2	95%
DC resistance standards and sources: Intermediate values	Fixed resistor	Potentiometric ratio bridge	1E+05	1E+06	Ω	4 to 41	μΩ/Ω	2	95%

# Capacitance Standards

## Fused Silica Standard Capacitors, 2 Sets

The unit of Capacitance is maintained by 2 Sets of Fused Silica Standard Capacitors that are traceable to the SI units by calibrating them at the BIPM.



Values: 1 pF, 10 pF and 100 pF.  
Exp. Uncer. = 0.63  $\mu$ F/F to 0.70  $\mu$ F/F

# Capacitance Standards

## Standard Air Capacitors

There are different values of General Radio and ietLab Air Capacitance standards, with values: 1 pF to 10  $\mu$ F.

Expanded Uncertainty = 0.8  $\mu$ F/F : 3.5  $\mu$ F/F



## Inductance Standards

There are different types of the inductance standards with different values, 10  $\mu\text{H}$  to 10 H. All of them are traceable to NPL.

(NPL) Expanded Uncertainty = 80  $\mu\text{H}/\text{H}$  : 310  $\mu\text{H}/\text{H}$



# Capacitance Measurement

## AH 2700A Ultra Precision Capacitance Bridge

Highly accurate capacitance measurements are carried out using the shown Ultra Precision Capacitance Bridge with (opt. E, opt. C) which is the first copy of this version in the world.

Range : 0.8 aF to 1.5  $\mu$ F



# Capacitance and Inductance Measurement

## E4980A Precision LCR Meter, (Agilent)



Measurement Parameters:  
Impedance parameters  $|Z|$ ,  $|Y|$ ,  $L_s$ ,  $L_p$ ,  
 $C_s$ ,  $C_p$ ,  $R_s$ ,  $R_p$ ,  $X$ ,  $G$ ,  $B$ ,  $D$ ,  $Q$

Manufacturer Specifications:  
Capacitance: 1.000000 aF to 999.9999 EF  
Inductance : 1.000000 aH to 999.9999 EH  
Resistance : 1.000000 a $\Omega$  to 999.9999 E $\Omega$   
@ Frequencies 20 Hz to 2 MHz  
\* a =  $10^{-18}$       \* E =  $10^{18}$

## Capacitance Comparisons

In 2016, NIS participated in Bi-Lateral BIPM.EM-K14.a, and b. Comparisons. Draft B had been finished, and the final report is under review.

### Bi-Lateral Comparisons of 10 pF and 100 pF Standards

Quantity	Instrument or Artifact	Method of Measurement	Min. value	Max. value	Units	Value	Units	Coverage Factor	Level of Confidence
Capacitance : low-loss capacitors	Fused Silica Capacitors	Direct method	10	100	pF	0.63 to 0.70	μF/F	2	95%



# AC/DC Voltage and Current

The AC/DC voltage and current standards are traceable to NIST (USA) and PTB (Germany).

AC/ DC Voltage transfer standard Meas. range is 0.3 V- 1000 V @ 10 HZ- 1 MHz

There are sets of

- Single- Junction Thermal Voltage converters (TVCs), and two
- Multi-Junction TVCs



Single Junction Thermal Voltage Converter Set



Multi Junction Thermal Voltage Converter

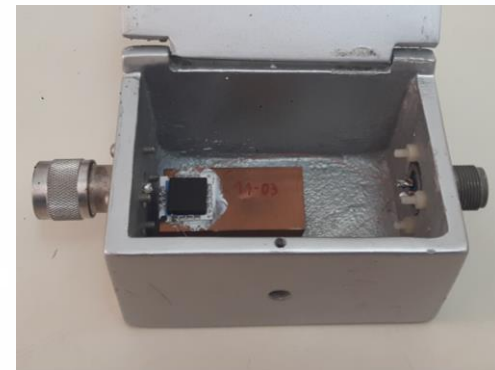

# AC/DC Voltage and Current

➤ Micro potentiometer ( $\mu\text{p}$ ):  
2 mV-500 mV @ 10 Hz- 100 kHz



❑ AC Current transfer standard:  
5 mA – 20 A @ 10 Hz- 100 kHz



Holt Current Shunt

TCC (Thermal Element + Current Shunt)

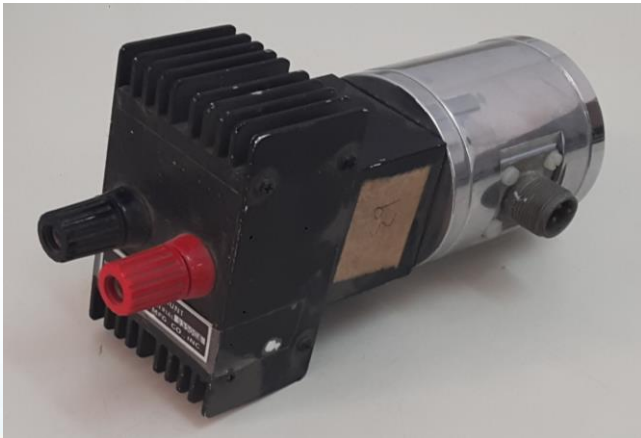

Fluke Current Shunts



# AC/DC Voltage and Current

## Recent Project : "Fabrication and Characterization of Precise System for Generating Low-Level AC Voltage Signals"

- As a part of the framework of the executive program of Scientific and Technological Cooperation between Italy and Egypt, this project has been initiated between NIS, Egypt and I.N.Ri.M., Italy.

## Inter-laboratory Comparison in Measuring Low Levels of AC Voltage between Italy and Egypt

**H. A. Mageed , R. S. M. Ali , N. N. Tadros , M. Halawa and M. Lanzillotti**  
MAPAN-Journal of Metrology Society of India, 2013

# AC/DC Voltage and Current

NIS participated in SIM.EM-K12 comparison, and the final report is already published ([Link](#)).

## SIM Regional Comparison of AC-DC Current Transfer Difference

Values (10 mA, 5 A) @ Frequencies (10 Hz, 55 Hz, 1 kHz, and 10 kHz).

Quantity	Instrument or Artifact	Method of Measurement	Min. value	Max. value	Units	Value	Units	Coverage Factor	Level of Confidence
AC/DC current transfer difference	AC/DC transfer standard plus shunt	Comparison with another AC/DC transfer standard	10 m	5	A	2.7 to 17.3	$\mu\text{A}/\text{A}$	2	95%

# Electrical Quantities Metrology

## Common Capabilities

### 5720A Multi-Function Calibrator, (Fluke)

Manufacturer Specifications:

DC Voltage: 0 V to 1100 V

ADC Voltage: 0.22 V to 1100 V @ 10 Hz to 1 MHz

DC Current: 0 A to 11 A (with 5725A Amplifier)

AC Current : 0 A to 11 A @ 10 Hz to 10 kHz

Resistance : 0 to 100 M $\Omega$ , 18 values in x1 and x1.9



# Electrical Quantities Metrology

## Common Capabilities

### 8508A 8.5 Digit Reference Multi-meter Calibrator, (Fluke)

Manufacturer Specifications:

DC Voltage: 0 V to 1050 V

ADC Voltage: 2 mV to 1050 V @ 1 Hz to 1 MHz

DC Current: 0 A to 20 A

AC Current : 0 A to 20 A @ 1 Hz to 100 kHz

Resistance : 0 to 20 GΩ



# Electrical Quantities Metrology

## Common Capabilities

There are some other meters, sources and old bridges





# Electrical Quantities Metrology

## Comparisons for Common Capabilities

### P1-APMP.EM-S8 Digital Multi-meter Comparison

➤ P1-APMP.EM-S8 Preparatory Workshop, 8-10 November 2010, Bangkok –Thailand.  
Attended by Assoc. Prof. Dr. Hala Abd Elmegeed.

➤ Comparison Measurements:

The comparison measurements were done from 8-10-2012 to 14-11-2012.

➤ P1-APMP.EM-S8 Concluding Workshop, 5-7 November 2015, Beijing China.

Attended by Prof. Dr. Nadia Nassif Tadros.

➤ On March, 10 2016, the final report has been sent to the supporting team assigned during the concluding workshop to support the initial team in the analysis of the data; this report contained all additional information requested during the concluding workshop.



# High Voltage Metrology

## Power and Energy

### Primary Standard for Electrical Power & Energy



This unit has the Primary Standard of Power & Energy Measurements (2100B) which is designed to generate voltages up to 600 V and currents to 100 A at any power factor.

Manufacturer Specifications:

Range: 600 V, 100 A

Expanded Uncertainty: <30 ppm

➤ Recently in 2017, the Lab Staff had a training for two weeks on the operation and the Uncertainty Calculations of this device by the TÜBİTAK UME, Turkey. EU funded twinning project

# Power and Energy



## Reference Standard for Power & Energy Meters

Manufacturer Specifications:

Range: 320 V, 1200 A

Expanded Uncertainty: <100 ppm

## High voltage



➤ AC/ DC High Voltage Measuring Instrument up to 100 kV with Exp. Uncer. = 0.052%

➤ AC/DC High Voltage Measuring Instrument up to 200 kV with Exp. Uncer. = 0.17%

➤ AC High Voltage Measuring Instrument up to 400 kV.

➤ AC/ DC High Voltage Source up to 200 kV.

➤ AC Dielectric Test Set up to 100 kV



## High Voltage - Tests



Transformer Turns Ratio  
Meter: 10 - 40 - 100 V



Oil Tester: 90 kV



High Resistance Decade Box:  
611 GΩ at 5000 V



Calibrator for Calibration of PD Calibrators:  
2000 pC

# High Current

AC/ DC High Current Power Source:  
5000 A AC, 2000 A DC



Current Transformer Test Set:  
5000 A AC Primary Injection Current



# High Voltage & High Current - Tests



Multifunction Calibrator with High  
Current Coils: 1000 A AC, 1000 A DC

Power Quality Analyzer:

600 V, 5000 A



Digital Multi-meter:  
1000 V AC, 1000 V DC

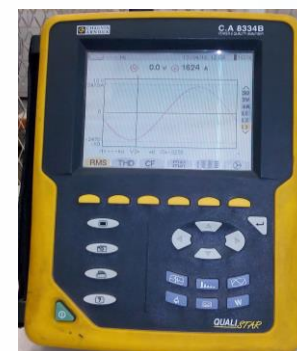

AC/ DC Digital Clamp Meter:  
2000 A AC, 2000 A DC

# Microwave Metrology



## NIS Microcalorimeter The Primary Standard of High Frequency Power Measurements

Type: Twin

Power Range : 1 mW to 10 mW

Connector: Precision N Type

Sensor Type : Thermistor

Operating freq. : 10 MHz to 18 GHz

# NIS Microcalorimeter Verification

“New Effective Coaxial Twin-Load Microcalorimeter System”\*

Yaser S. E. Abdo, Murat Celep

A new coaxial twin-load microcalorimeter has been installed at NIS.

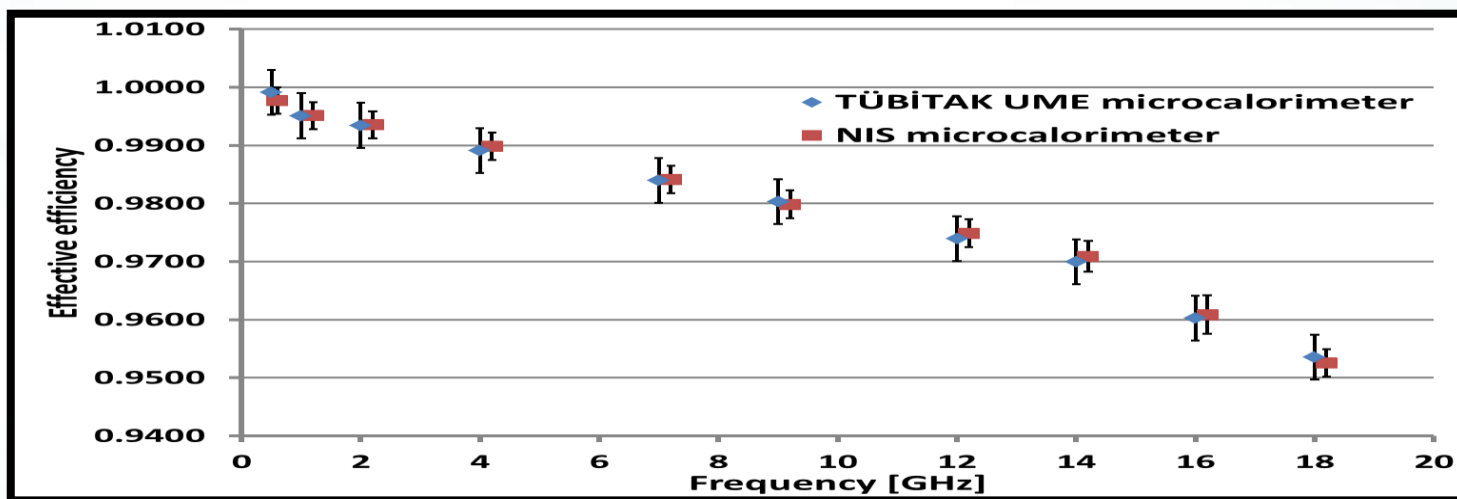

A comparison between these measured values and the corresponding effective efficiency measured by the microcalorimeter setup of the national metrology institute of Turkey (TÜBİTAK UME) was done to validate the accuracy of the new setup.

\* Conference on Precision Electromagnetic Measurements CPEM, July 2016.



# Microwave Metrology



Microwave Lab. is capable to characterize the microwave circuits (S-parameters, reflection coefficient for all ports and their transmission coefficients, return loss, and Frequency Range: 10 MHz to 40 GHz

# Microwave Metrology

## Distortion and Harmonic Content

Microwave Lab. is capable to measure distortion and signal harmonics using a spectrum analyzer.

Frequency Range: 9 KHz to 30 GHz

Level Range: -90 dBm to 30 dBm

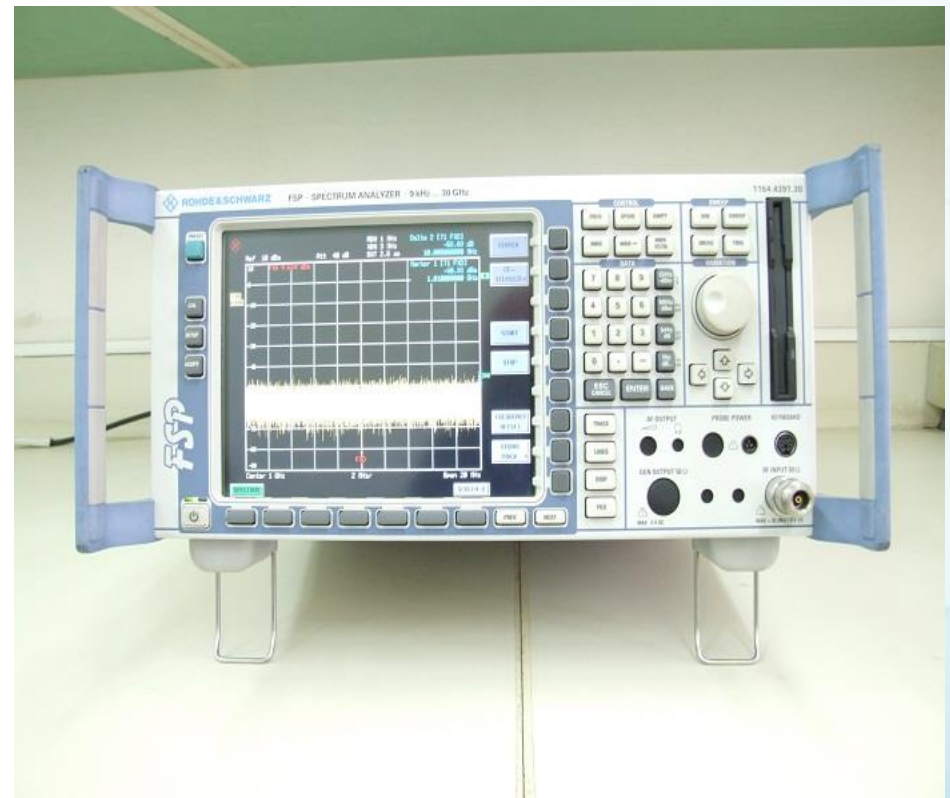

# Microwave Metrology

## RF Power Measurements

Direct Power Measurements

*Frequency Range: DC to 40 GHz*

*Range: -35 to 20 dBm*



# Microwave Metrology

## Electromagnetic Field

### Electromagnetic (EM) Radiation Safety Levels:

*Electric field range from: 1-300 V/m*

*Frequency Range: 0.5 MHz to 5 GHz*

- Microwave Lab. can test the safety levels of the EM fields radiated from the mobile phone base-stations, and any other EM fields sources.

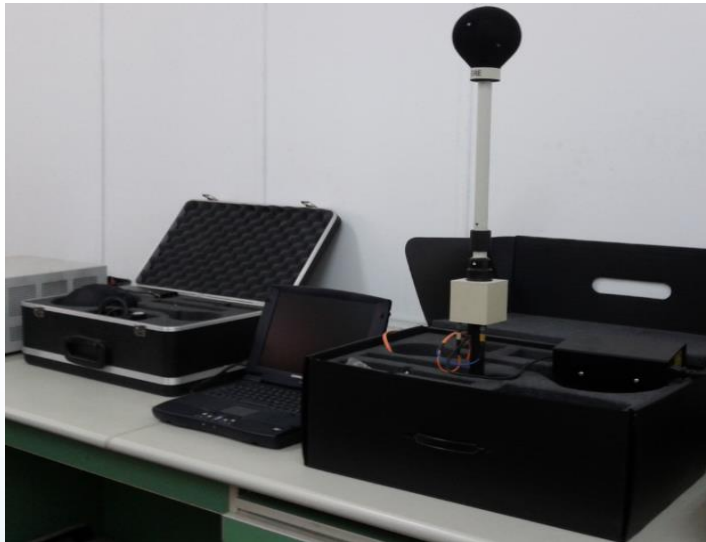

# Microwave Metrology

## Research project:

- EMPIR -15RPT01 (RFMicrowave): "Development of RF and microwave metrology capability", which is funded by the European Union's Horizon 2020 research and innovation programme.

## Planned Comparisons :

- AFRIMETS.EM.RF-S1: Attenuation and reflection for coaxials.
- EURAMET comparison, effective efficiency of thermistor mounts, had been proposed through the TCEM SC-RF&MW, 2015.



# Activities with AFRIMETS

## AFRIMETS TC-EM Meeting, 7– 2016, EGYPT



Tow NIS members were attended.



## Activities with AFRIMETS

- Assoc. Prof. Dr. Mohammed Helmy, NIS, EGYPT was elected as the TCEM Vice Chairperson.
- Assoc. Prof. Dr. Mohammed Helmy assists in the review of the CMCs as one of the CIPM MRA activities.
- Prof. Dr. Nadia Nassif assisted as a Technical and quality Expert in the review of the Laboratoires of DEFNAT, Tunisia as fit for purpose of CIPM MRA, for AFRIMETS TCQS.
- Eng. Heba A. hmed Joined the AFRIMETS School of Metrology 2011, as a participant in Nairobi, Kenya.
- NIS will participate in the next TCEM meeting in South Africa.



## Planned Comparisons

Year	Identifier	Description	Participants	Pilot	Status
2015	AFRIMETS.EM-S1	DC resistance at 1 $\Omega$ , 10 $\Omega$ , 100 $\Omega$ , 1 k $\Omega$ and 10 k $\Omega$	NMISA, LPEE/LNM, DEF-NAT, KEBS, NIS, SIRDC-NMI, UNBS, ZABS	NMISA	Ongoing
2017	AFRIMETS.RF-S?	RF attenuation	NMISA, NIS, DEF-NAT	NMISA	Planned
2018	AFRIMETS.EM-K?	DC voltage at 1,018 V and 10 V reference	NMISA, LPEE/LNM, DEF-NAT, KEBS, NIS	NIS	Planned
2019	AFRIMETS.EM-S?	Digital Multimeter, ACV: 200 mV, 200 V @ 40 Hz and 1 kHz. ACI: 100 mA, 1 A @ 40 Hz and 1 kHz. DCI: 10 mA and 1 A. DCV:100 V and 1000 V	NMISA, LPEE/LNM, DEF-NAT, KEBS, NIS	DEF-NAT	Planned
2020	AFRIMETS.EM-K?	AC Power and energy	NMISA, LPEE/LNM, DEF-NAT, KEBS, NIS	NIS	Planned
2021	AFRIMETS.EM-S?	AC-DC transfer	NMISA, DEF-NAT, NIS	NMISA	Planned

# Main Important Recent Researches and Patents

**Lists of publications and more details  
are provided in a written report  
“CCEM-17-Report-NIS”**

# Patents

[www.egypo.gov.eg](http://www.egypo.gov.eg) , [patinfo@egypo.gov.eg](mailto:patinfo@egypo.gov.eg)

1. Mohammed Helmy A. Raouf, “Decade Resistance Formed by Minimum Number of Elements”, Ministry of Higher Education and Scientific Research, Patent Office, Cert. No. 24567, October 2009.
2. Mohammed Helmy A. Raouf, “Decade Inductance Formed by Minimum Number of Elements”, Ministry of Higher Education and Scientific Research, Patent Office, Cert. No. 24447, July 2009.
3. Mohammed Helmy A. Raouf, “Decade Capacitance Formed by Minimum Number of Elements”, Ministry of Higher Education and Scientific Research, Patent Office, Cert. No. 24446, July 2009.

## Patents

4. Mohammed Helmy A. Raouf, “Automated Decade Inductance of Fifteen Output Values”, Ministry of Higher Education and Scientific Research, Patent Office, Cert. No. 26576, March 2014.
5. Mohammed Helmy A. Raouf, “Automated Decade Resistance of Fifteen Output Values”, Ministry of Higher Education and Scientific Research, Patent Office, Cert. No. 26493, December 2013.
6. Mohammed Helmy A. Raouf, “Automated Decade Capacitance of Fifteen Output Values”, Ministry of Higher Education and Scientific Research, Patent Office, Cert. No. 26040, December 2012.



Academy of Scientific Research and  
Technology  
(ASRT)



Arab Republic of Egypt  
Ministry of State for Scientific Research

### Official Extract of Patent No. 26493

President , ASRT

Under the Article No. 19 of the Intellectual Property Rights of law No. 82 of the year 2002, and the Presidential decree No. 377 of the year 1998 for reorganizing the Academy of Scientific Research and Technology and in accordance with patent application No. 2009030327 and the documents attached to it : Decided

- Article 1* : A patent No. 26493 is granted To A.Prof. Dr. Mohammed Helmy Abd El-Raouf Mohammed
- Address* : National Institute For Standards, Tersa St. El-Haram, Giza, Egypt
- For the invention* : Fifteen Values Automated Decade Resistance Fabricated By Optimum Number Of Elements
- Inventor Name* : A. Prof. Dr. Mohammed Helmy Abd El-Raouf Mohammed
- Patent Period* : 20 years, Starting on 12 March 2009, a certified description of this patent is attached to this certificate
- Article 3* : This decree was issued in Cairo on 19 December 2013  
: The concerned authority must publish the issuance of this patent in the Egyptian Patent Gazette

Granting this Patent does not give the right to market the product in the Arab Republic of Egypt. To market the product of this patent in the Arab Republic of Egypt, legal regulations and procedures specified by the concerned Ministries must be followed

President,Of  
Egyptian patent office  
Adel E. Ewida



President Of ASRT  
Prof. Dr. Mahmoud Mohamed Sakr

# Design, Implementation, and Characterization of a New Resistance Box Fabricated with Fifteen Outputs Decades

**M. Helmy A. Raouf**

Measurement , 101 (2017) 206–210

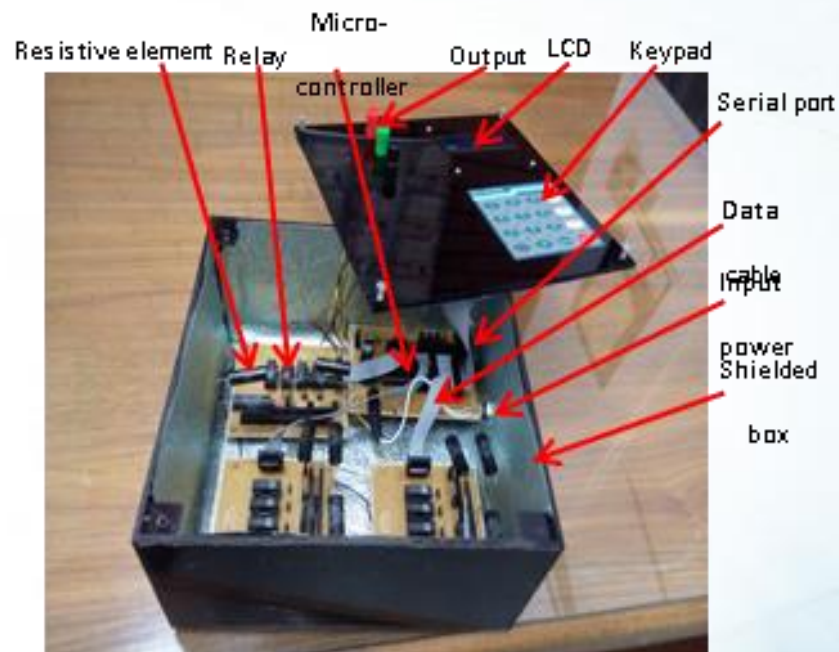
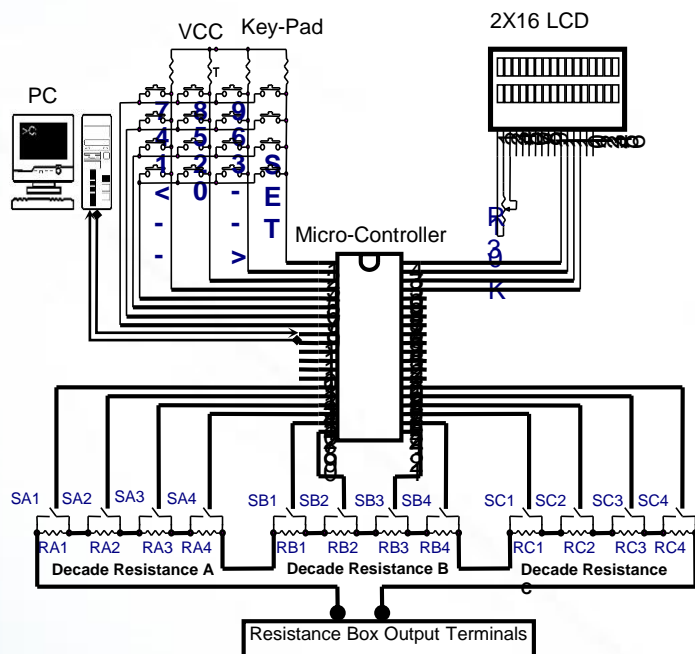

- The New fabricated resistance box has been constructed using three decades with 12 resistors connected to their corresponding 12 reed relays and controlled by only one microcontroller.
- 4096 resistance steps could be obtained by all possible combinations, but 1666 of them are different from each other. The minimum number of the used resistive elements leads to minimum power losses, cost, and maintenance effort with better electrical properties and performance.
- The relative deviation of output resistance steps from their rated values is less than or equal  $\pm 50$  ppm, whereas the relative uncertainty because of the summation effect is less than or equal  $\pm 6.0$  ppm.
- The huge number of the output resistance steps enables the new resistance box to be used dependably for manual and fully automated calibrations of the resistance meters and their linearity checking.

# New Internal Multi Range Resistors for AC Voltage Calibration by using TVC

**Rasha Sayed A. Mohammed**

Measurement Science and Technology Journal, Vol. 26, No. 10, Oct., 2015

- Multi-range internal range resistors are designed and implemented in the National Institute for Standards (NIS), Egypt to cover the ac voltage ranges from 10 V to 750 V.
- The range resistor values are 2 k $\Omega$ , 10 k $\Omega$ , 20 k $\Omega$ , 40 k $\Omega$ , 100 k $\Omega$ , and 150 k $\Omega$  to cover the voltage ranges 10 V, 50 V, 100 V, 200 V, 500 V, and 750 V respectively.

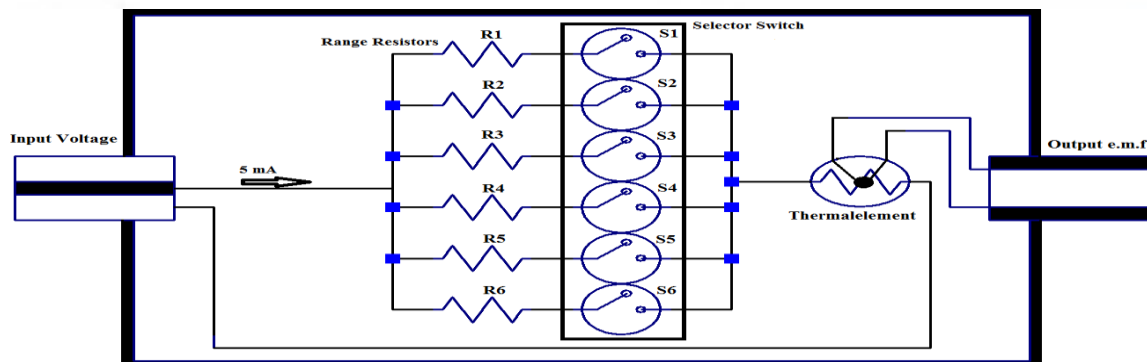



- The six range resistors are mounted in series with a single-junction thermoelement in the same box to provide a new thermal voltage converter.
- The required range resistor is selected by using a 6-pin selector switch. Each resistor is connected to a selector pin.

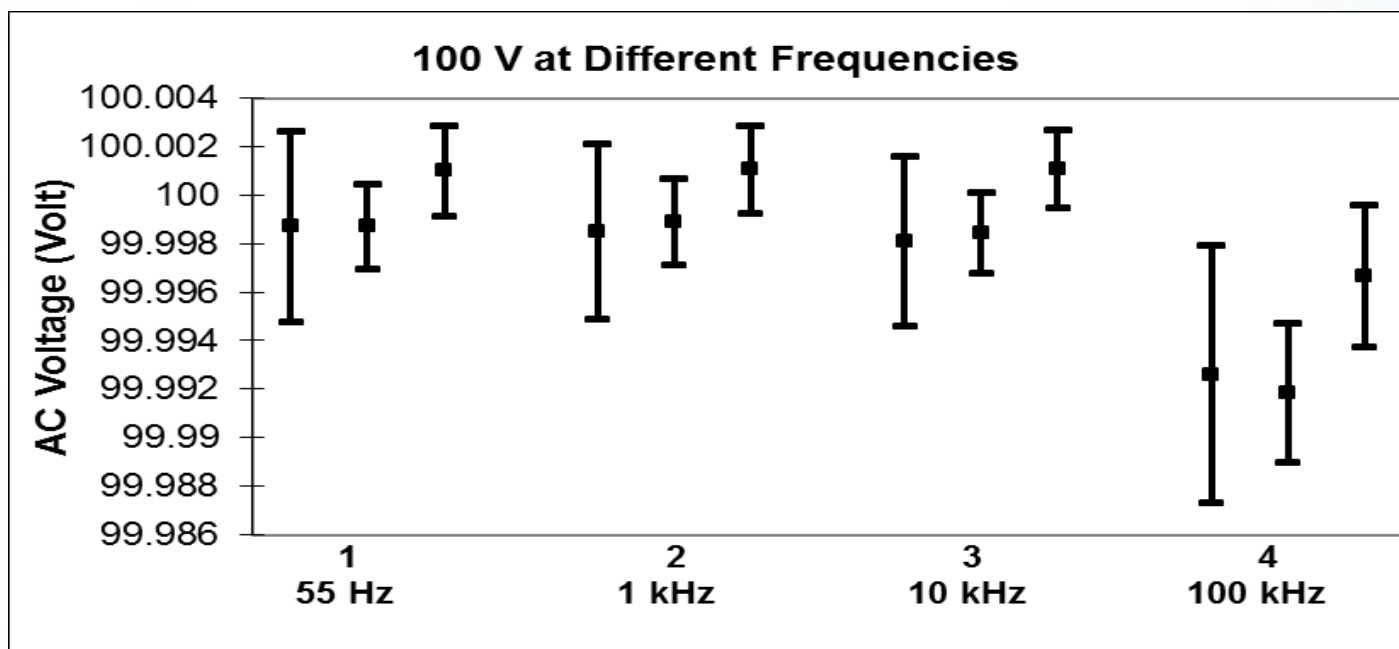

- The advantage of the internal range resistors combined with the thermo-element is the removal of the contact resistance between the range resistor connector and the thermo-element connector.
- It also protects the connector from wear due to repeat connection cycles. The implementation of multi-range internal range resistors limits the number of TEs and reduces the cost.
- It is shown that the measured values using the new TVC are in agreement with the results obtained from the ac voltage calibration at Fluke and closer to it than the traditional TVC. It indicates that the new TVC is more accurate and has a better performance than traditional TVCs.



# Automated accurate high value resistances measurement in the range from 100 k $\Omega$ to 100 M $\Omega$ at NIS

**Nadia N. Tadros, Rasha Sayed M. Ali**

**Measurement , Volume 45, Issue 5, June 2012**

- This paper describes the procedures made at NIS for the first time to establish accurate resistance measurements for high value resistance standards in the range from 100 k $\Omega$  to 100 M $\Omega$ .
- 10 k $\Omega$  (NIS Standard) and Guarded Hamon transfer standards (100 k $\Omega$ , 10 M $\Omega$ ) have been used at NIS for scaling to high resistance levels up.
- The used method at NIS for the high resistance measurements, above 100 k $\Omega$ , is the DMM-based method which works automatically.
- A new software is made especially for this purpose.
- The automatic measurement improved the quality of the calibration, eliminating the noise due to the operator and errors that result from transcribing data.

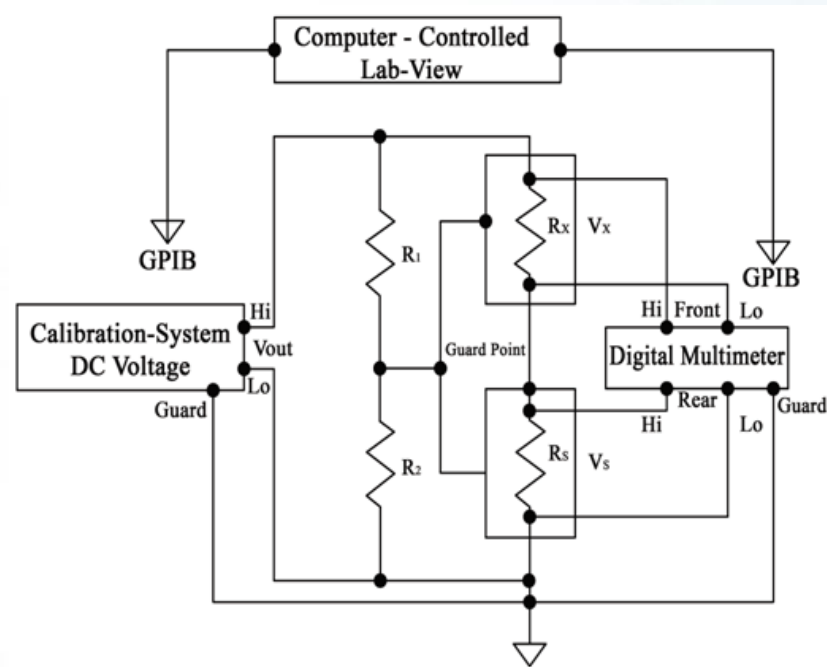
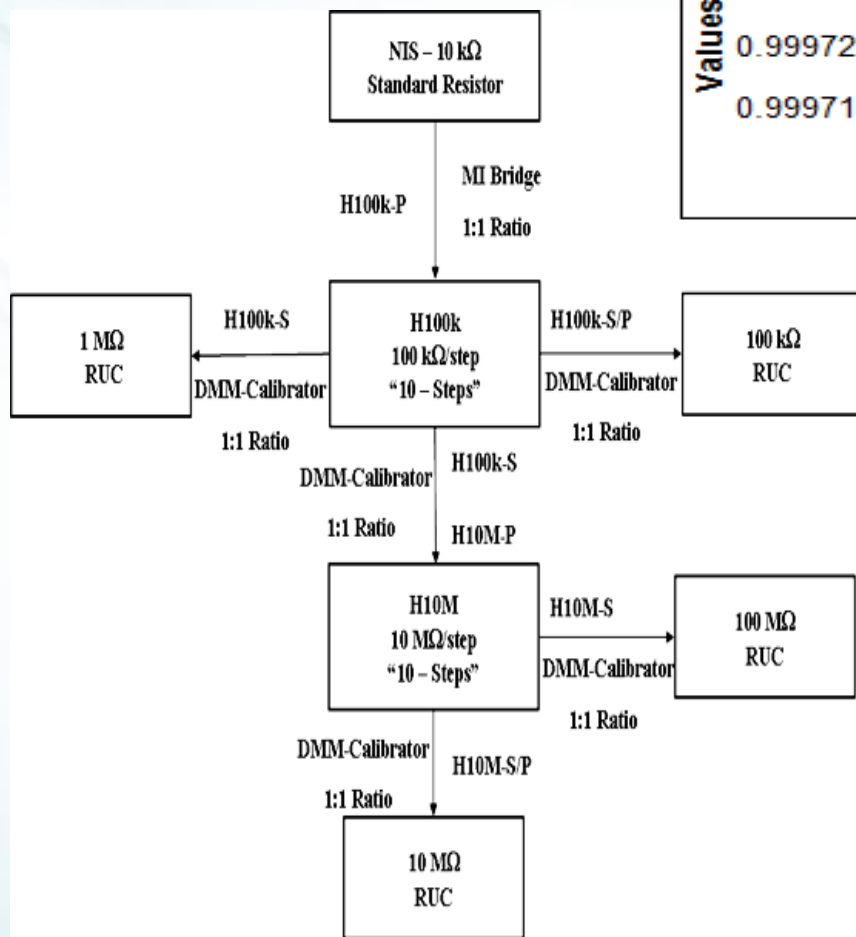
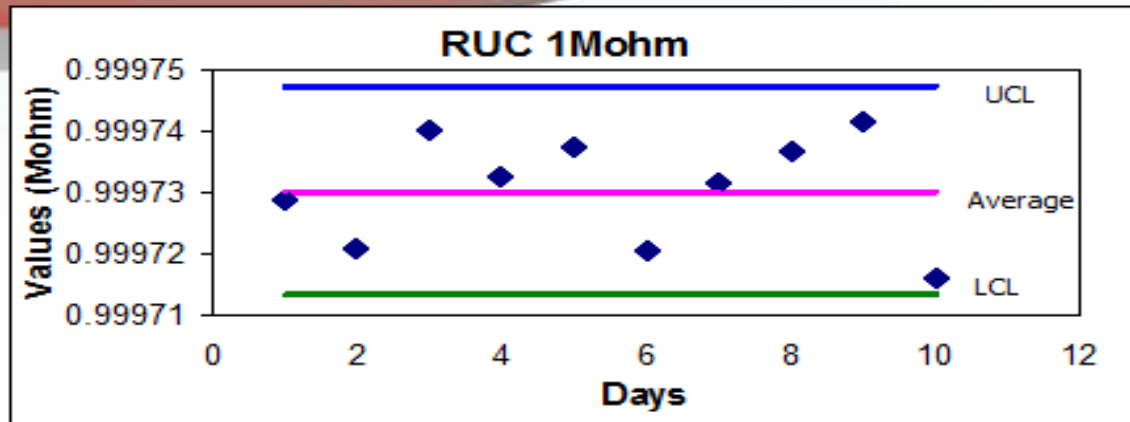



# Improved System for the automatic calibration of standard resistors in the meg-ohm range

**Rasha Sayed M. Ali , Nadia N. Tadros**

**Measurement , Volume 46, Issue 7, August 2013**

- The automated measuring system is developed for improving the calibration of high value standard resistors in the meg-ohm range (100 k $\Omega$  to 100 M $\Omega$ ) at the NIS.
- DMM-based method by the substitution technique where the unknown resistor and the standard resistor are indirectly compared in the same position using a dummy resistor.
- The system operation is automatically controlled by using a LabVIEW program which is especially developed for this purpose.
- The performance of this system is also evaluated by comparing the measurement results obtained from this technique with those obtained by the direct comparison DMM-based method. It is found that the span of the expanded uncertainty of measurement with this method is from 4.1  $\mu\Omega/\Omega$  to 27  $\mu\Omega/\Omega$ , whereas its span is from 40  $\mu\Omega/\Omega$  to 110  $\mu\Omega/\Omega$  for the direct comparison method.

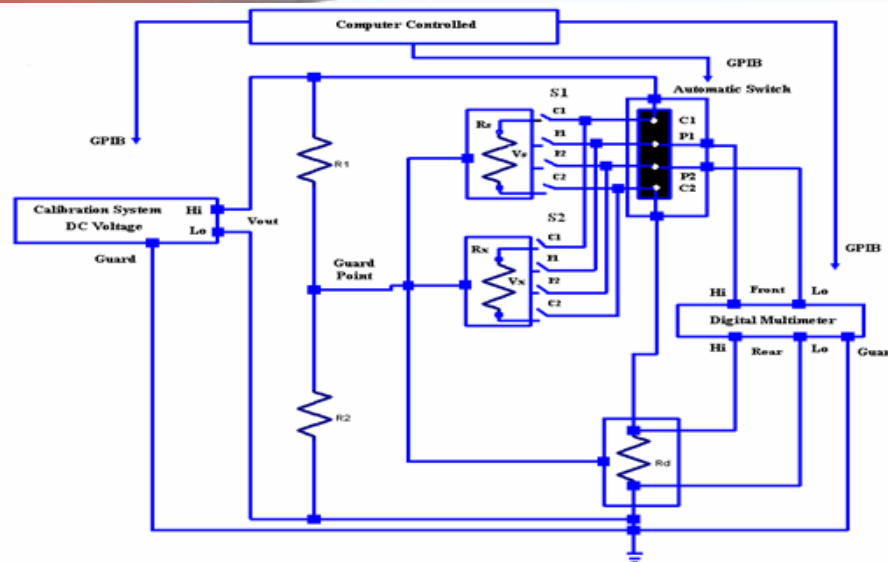
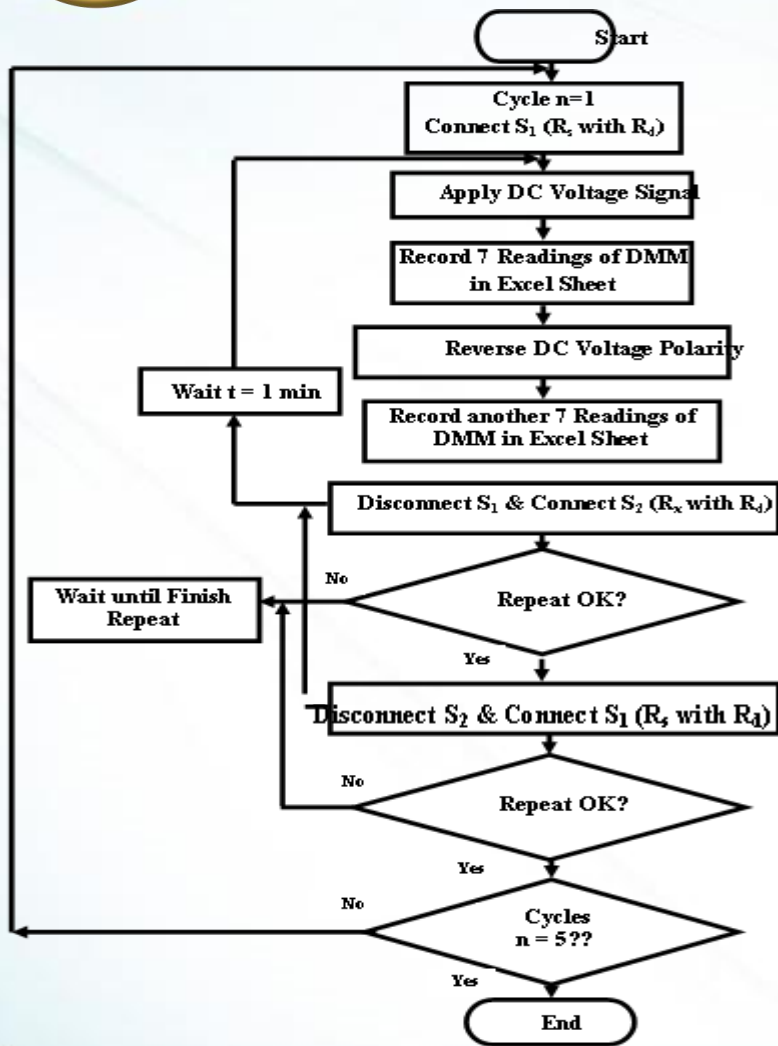

Method	Relative Uncertainties, $\mu\Omega/\Omega$	Nominal Value			
		100 k $\Omega$ M $\Omega$	1 M $\Omega$ 100 M $\Omega$	10	10
Substitution Method	Type A	0.04	0.41	0.3	0.75 1
	Type B	2	8	11	13
	Exp. Uncertainty (k=2)	004.1	18	23	27
Direct Comparison Method	Type A	2.3	4.8	8.5	13
	Type B	20	24	44	52
	Exp. Uncertainty (k=2)	40	48	89	110

# Measurement of Capacitance and Resistance Using Two Perfectly Synchronized Voltage Sources

**M. Helmy A. Raouf et al.**

**Measurement 60 (2015) 174–177**

- The introduced programmable bridge is very easy to be established avoiding many problems of voltage and phase control, with minimum effects of connections and cables.
- It has been used to determine capacitance to resistance ratio as well as resistance to resistance ratio within  $10^{-5}$  accuracy level.
- The bridge asymmetry error is in the order of  $10^{-7}$  with high quality measured standards.
- Evaluated expanded uncertainty is less than 11 ppm, for both in – phase and quadrature – phase measurements.

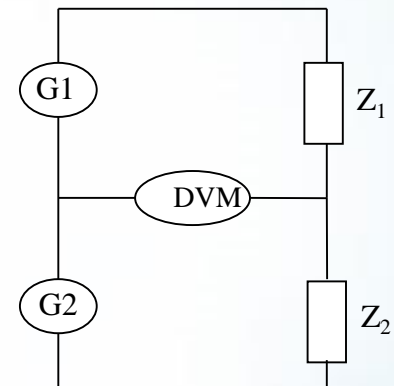

# Traceability of DC high voltage measurements using the Josephson voltage

**Hala M. Abdel Mageed, Ali M. El-Rifaie and Omar M. Aladdin**  
Measurement, 2014

- A new calibration technique has been used at NIS for disseminating the traceability to the high voltage DC measurements (up to 100 kV) via the NIS automated 10 V DC Josephson Voltage Standard (JVS).

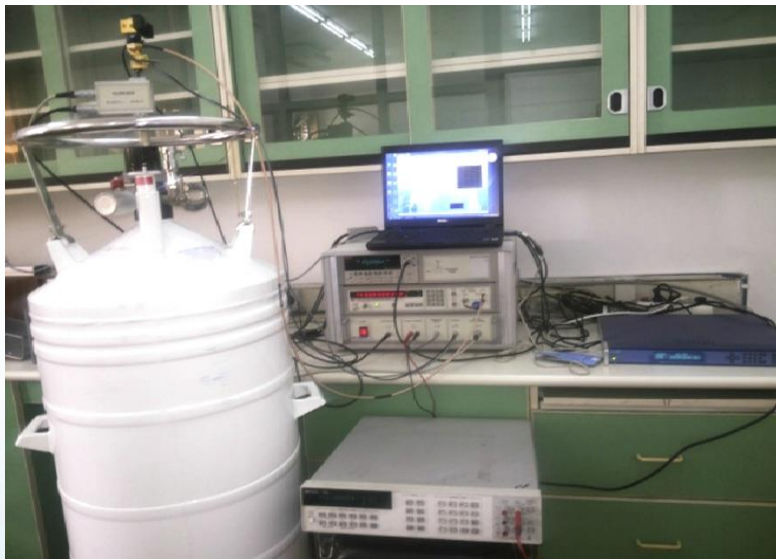



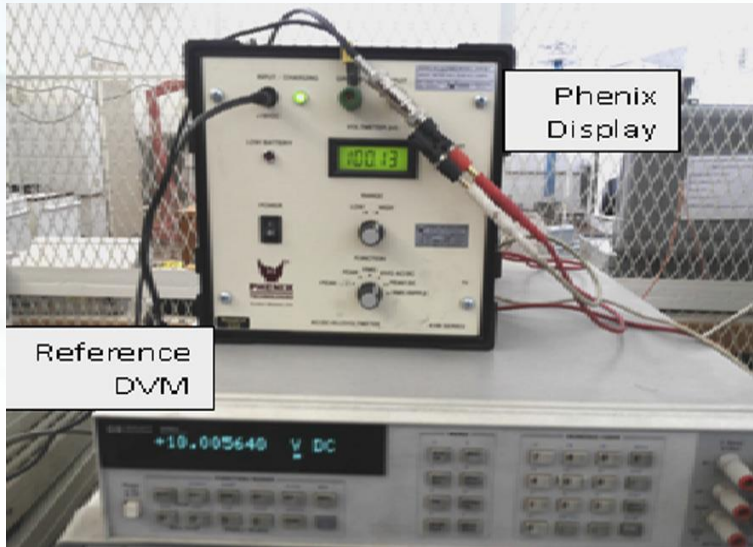

- The expanded uncertainty has a maximum value of 0.06% for the low range measurements (1–10 kV), while it decreases to about 0.05% for the high range measurements (20–100 kV).

The background features a gradient from red on the left to blue on the right. Overlaid on this are several semi-transparent, overlapping gauges. One prominent gauge in the center has a needle pointing towards the 10 o'clock position. It is labeled 'therm' at the top and 'bar' at the bottom. Other gauges are partially visible, showing scales with numbers like 2, 3, 4, 9, and 10.

**THANK YOU**