

NEW GENERATION SYSTEM OF JAPAN STANDARD TIME AT NICT

National Institute of Information and Communications Technology (NICT)
Koganei, Tokyo, Japan

1. Introduction

NICT has developed a new generation system of Japan Standard Time (New JST system), at the opportunity when the system moves to a new building. There are various renewals in the New JST system. For example, hydrogen masers are adopted as signal sources instead of cesium atomic clocks and newly developed DMTD (Dual Mixer Time Difference) systems are introduced for the measurement of clocks' time differences. Its project started in 2002 and the system has completed in February 2006. During this period, we kept the UTC(NICT) in the old building and conducted a performance test of a new system in the new building. This parallel operation was good to evaluate the quality of the new system. The New JST system has started to operate regularly from February 7, 2006.

2. New JST system

The outlook is presented in Fig.1 and the block diagram is shown in Fig.2. The features of this system are described as follows.

2.1 Clocks, TA(NICT) and UTC(NICT)

We have 18 cesium atomic clocks (HP5071A with high performance tube) and 4 hydrogen masers (RH401A, Anritsu Corp.). This is the first time to use hydrogen masers in a JST system. This hydrogen maser has a short-term frequency stability of 2×10^{-13} at 1sec and auto-tuning function.

TA(NICT) is calculated by using 18 cesium clocks. Hydrogen masers have not been used for the calculation yet. We estimate the rates of cesium clocks according to the latest 30days. TA(NICT) is calculated every an hour. The signals of UTC(NICT) are generated from a frequency adjuster (AOG, Auxiliary Output Generator) which uses a 5 MHz of hydrogen maser as a reference. We adjust the frequency of AOG once a day at UTC 1:20 so that UTC(NICT) traces the TA(NICT). Occasionaly some offset may be added to keep UTC(NICT) close to UTC. The rate of the reference hydrogen maser is



Fig. 1 NJST system
(excluding the atomic clocks and the computers)

estimated from the data of the latest 5 days and canceled at the frequency adjusting.

2.2 Measurement system

The time difference among the clocks is measured by using a newly developed 24ch-DMTD system (Nihon Tsushinki Corp., see Fig.3). It uses a hydrogen maser's 5MHz as a reference, and other clocks' 5MHz as DUTs. The down-converted frequency is 1kHz. It generated the average of 100 measurements every second. However, we use the hourly representative value obtained by a linear fitting of 2-hour-data. The measurement precision in 100 ms gate time is 0.2ps. In the previous JST system, several inputs were switched and serially measured, so the data were not simultaneous. We can measure 24 data simultaneously with the New JST system, which suppresses measurement errors caused by the different timing of measurement.

The measurement of 5MHz by DMTD system has a high precision. However, it sometimes causes a phase ambiguity if cycle-slips are miscounted. Phase discontinuity may occur after the lack of data in a long period. In order to avoid this problem, we use 1PPS measurement by a time interval counter to which adds the DMTD measurement. We adopt counter's results to define the initial phases, and accumulate the frequency obtained from the DMTD's results after that. This method is effective to obtain a high measurement precision and a reliability of the phases.

2.3. Redundancy

There are triple redundancies in the signal generation parts (H maser and AOG), and we select one of them as the master of UTC(NICT). As their outputs are usually synchronized with some nanoseconds, a sudden change of the master doesn't cause a large jump. Though the automatic change of master is technically possible, its procedure needs a person in charge of judgment now.

The measurement parts are equipped with three DMTD systems and one time interval counter, so we obtain four results by one measurement. We choose the closest two values which are used for the time scale calculation. Two DMTDs are usually selected, but the counter is selected, if there are no DMTD data. This process is automatic and we can obtain the measurement data, if at least one of four devices is operational. The comparison of four results is also effective to detect a system trouble rapidly.

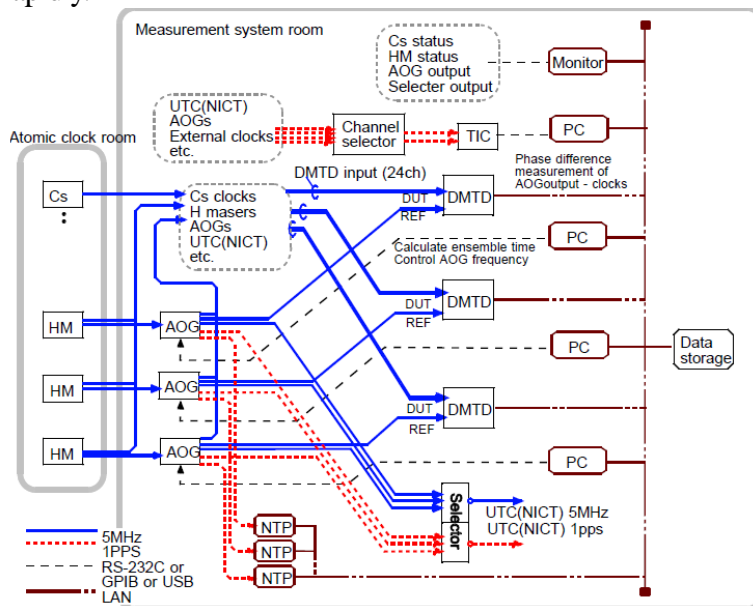

Fig. 2. Block diagram of the New JST system



Fig. 3. 24-ch DMTD system

2.4. Computers and monitoring system

The various tasks are divided to several PCs to decrease the risk of a total system down. We use Linux PCs as servers, and Windows PCs to control the devices. The measurement data and calculation results are managed by a database. The database server is equipped with a RAID system. The system clock is synchronized with UTC(NICT) by using NTP.

The conditions of systems such as room temperature and humidity, conditions of devices, and data acquisition processes, are regularly monitored. Accordingly abnormal statuses are notified by an alarm and an e-mail. The monitoring program is checked by web. Monitoring UTC(NICT) signals by oscilloscopes is newly introduced and is effective for rapid detection of troubles.

2.5. Environments

In the rooms for the atomic clocks, the temperature and humidity are kept at 24 ± 0.5 degree and at $40\pm 10\%$ respectively. The new building is equipped with a dynamo and a large UPS. All the electricity of the New JST system are supplied with this UPS. There are also DC batteries for the atomic clocks and the main devices. They can supply the electricity for several hours. This building also has a high security system and a quake-absorbing structure for a high reliability.

3. Current Status and future plan

Fig.4 shows the UTC-UTC(NICT) after New JST system started to be operational. The synchronization with UTC within 10ns is achieved. We think some investigations especially for the TA(NICT) calculation make the UTC(NICT) more stable. We also aim to link the TA(NICT) with our primary frequency standard and construct a better time-scale.

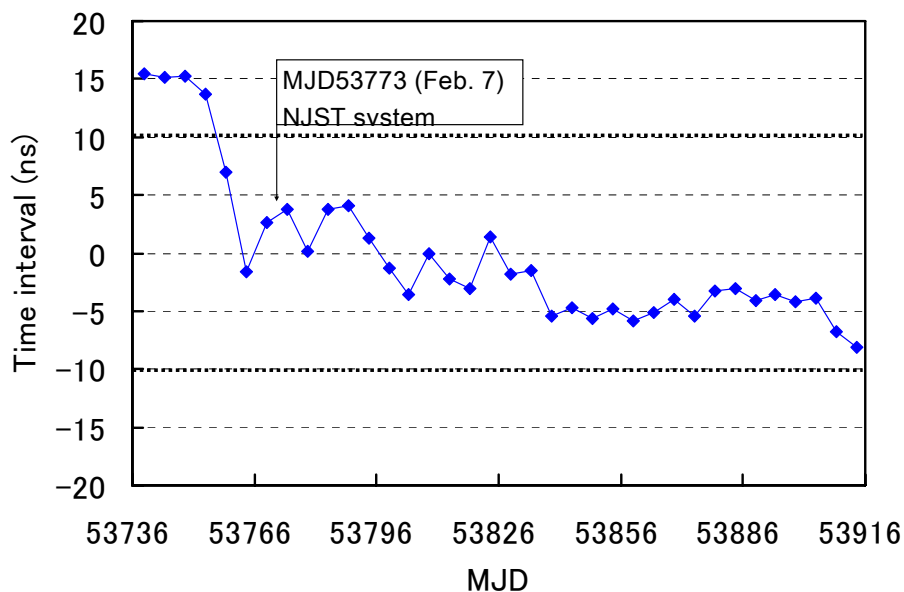

Fig. 4 UTC - UTC(NICT)