

Final Report

Inter-comparison of calibration of
a rotary piston gas meter G650

EURAMET Project No. 1590

**Supplementary comparison
EURAMET.M.FF-S20**



Flow

Tomáš Valenta, *Czech Metrology Institute*

Claudia Berkmann, *Bundesamt für Eich- und Vermessungswesen*

Adam Urbanowicz, *Główny Urząd Miar*

March 18, 2025



Contents

1. Introduction.....	3
2. Instrument	4
3. Calibration procedure.....	6
4. Test facility and obtained results	7
4.1. Czech Republic.....	7
4.2. Germany	9
4.3. Denmark	11
4.4. Netherlands.....	13
4.5. Austria	14
4.6. Poland.....	16
4.7. Lithuania.....	16
4.8. Sweden	20
4.9. Switzerland.....	21
5. Stability of the meter and the dependency of laboratories.....	22
6. Determination of the reference values in determined flow rates	23
6.1. The determination of the Key Comparison Reference Value (KCRV) and its uncertainty.....	23
6.2. The determination of the differences “Lab to KCRV” as well as their uncertainties and Degrees of Equivalence	25
7. Results.....	25
7.1. Czech Republic - Dependent laboratory (to PTB)	27
7.2. Germany - Independent laboratory.....	28
7.3. Denmark - Dependent laboratory (traceable to VSL)	29
7.4. Netherlands - Independent laboratory	30
7.5. Austria - Dependent laboratory (traceable to PTB).....	31
7.6. Poland - Independent laboratory	32
7.7. Lithuania - Dependent laboratory (traceable to PTB).....	33
7.8. Sweden - Independent laboratory.....	34
7.9. Switzerland - Independent laboratory	35
8. Summary and conclusion.....	36

1. Introduction

The project EURAMET no.1590 was a comparison of calibrations of the rotary piston gas meter G650. It officially started in December 2023 and was concluded in October 2024. The planned time schedule is shown in *table 1*. Each country took three weeks to perform the calibration of the rotary piston gas meter G650 with air in the pressure which is close to barometric pressure. The range of flow rates was from 50 m³/h to 1000 m³/h. The participating laboratories used their usual calibration procedure. The comparison was conducted with respect to guidelines²¹⁾²⁾.

In the moment when this report is issued, no CIPM key comparison was finished in the field of low pressure gas flow in relevant flow rates. That is why this inter-comparison is EURAMET supplementary comparison.

Table 1 – Time schedule and participants

Country	Laboratory	Address of the place of calibration	e-mail telephone	Date of calibration	Responsible person
Czech Republic (PILOT LAB)	CMI Czech Metrology Institute	Czech Metrology Institute Prumyslova 455 53003 Pardubice Czech Republic	tomas.valenta@cmi.gov.cz +420 466 670 728	11.12.2023 - 22.12.2023	Tomas Valenta
Germany	PTB Physikalisch- Technische Bundesanstalt	PTB Bundesallee 100 38116 Braunschweig Germany	Bodo.Mickan@ptb.de +49 531 592 1331	2.1.2024 - 19.1.2024	Bodo Mickan
Denmark	FORCE Technology	FORCE Technology Navervej 1 6600 Vejen Denmark	JRB@forcetechnology.com +45 22697620	22.1.2024 - 9.2.2024	Jesper Busk
Netherlands	VSL	VSL Thijsseweg 11 2629 JA Delft The Netherlands	twendel@vsl.nl +31631119906	12.2.2024 – 1.3.2024	Thomas Wendel
Austria	BEV Bundesamt für Eich- und Vermessungswesen	BEV Arltgasse 35 A-1160 Wien Austria	claudia.berkmann@bev.gv.at +43 1 211 10-826539	4.3.2024 - 22.3.2024	Claudia Berkmann

1) for CIPM key comparisons <https://www.bipm.org/documents/20126/43742162/CIPM-MRA-G-11.pdf>

2) for EURAMET comparisons – EURAMET Guide no.4 - <https://is.gd/1BCSrm>

Country	Laboratory	Address of the place of calibration	e-mail telephone	Date of calibration	Responsible person
Poland	GUM Główny Urząd Miar (Central Office of Measures)	Central Office of Measures 00-950 Warszawa P-10 ul. Elektoralna 2 Poland	adam.urbanowicz@gum.gov.pl +48 22 581 9319	25.3.2024 - 12.4.2024	Adam Urbanowicz
Lithuania	Lithuanian Energy Institute (Heat equipment research and testing laboratory)	Lithuanian Energy Institute Breslaujos st. 3 LT-44403 Kaunas Lithuania	arunas.stankevicius@lei.lt +370 68620850	15.4.2024 - 3.5.2024	Arūnas Stankevičius
Sweden	RISE Research Institutes of Sweden	RISE - Research Institutes of Sweden Industrigatan 4 SE-501 15 Borås Sweden	fredrik.niklasson@ri.se +46 70 549 53 94	6.5.2024 - 24.5.2024	Fredrik Niklasson
Czech Republic (PILOT LAB)	CMI Czech Metrology Institute	Czech Metrology Institute Prumyslova 455 53003 Pardubice Czech Republic	tomas.valenta@cmi.gov.cz +420 466 670 728	27.5.2024 - 14.6.2024	Tomas Valenta
Switzerland (ATA-CARNET)	METAS Metrology and Accreditation Switzerland	Federal Institute of Metrology METAS Laboratory for Flow and Hydrometry Lindenweg 50, 3084 Wabern-Bern Switzerland	marc.dehuu@metas.ch +41 58 387 02 67	17.6.2024 – 5.7.2024	Marc de Huu
Bosnia and Herzegovina a (ATA-CARNET)	Institut za mjeriteljstvo Bosne i Hercegovine	LABSAGAS KJKP Sarajevogas d.o.o Trg Fadile Odžaković 4 71000 Sarajevo Bosnia and Herzegovina	ibusuladzic@sarajevogas.ba	8.7.2024 – 26.7.2024	Ibrahim Busuladžić
Czech Republic (PILOT LAB)	CMI Czech Metrology Institute	Czech Metrology Institute Prumyslova 455 53003 Pardubice Czech Republic	tomas.valenta@cmi.gov.cz +420 466 670 728	29.7.2024 – 9.8.2024	Tomas Valenta

Due to unexpected problems with customs clearance and the ATA CARNET document, the gas meter had to be returned to CMI (pilot laboratory) during the project and was not subsequently sent to Bosnia and Herzegovina.

2. Instrument

An rotary piston gas meter (*Figure 1* and *Figure 2*) was used for the comparison. The description of this meter is mentioned down.

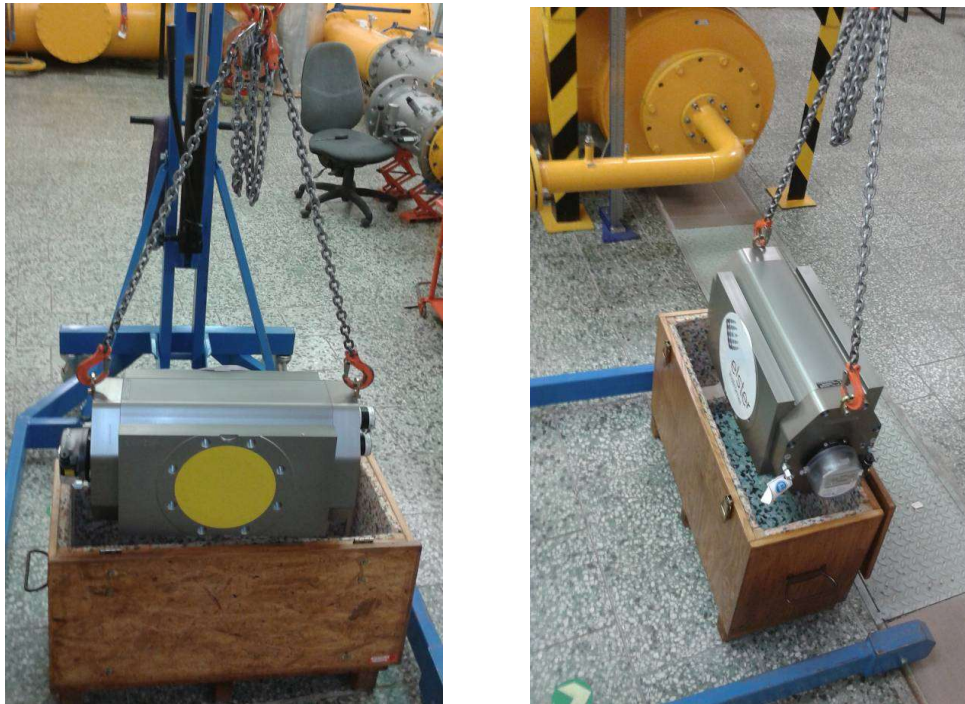

Figure 1 – Rotary piston gas meter ELSTER-INSTROMET IRM-3-DUO G650



Figure 2 – Pulse connector of rotary piston gas meter ELSTER-INSTROMET IRM-3-DUO G650

The specifications of the meter are mentioned in *table 2*.

Table 2 - Specifications of the meter

Manufacturer: ELSTER INSTROMET, Stará Turá, Slovak Republic	
EC-type examination certificate: T10198 (NMI)	P_{max} : 16 bar
Size: G650	Inside diameter: DN150
Q_{min} : 6 m ³ /h	Q_{max} : 1000 m ³ /h
Weight: approximately 62 kg	Pulse number: 450.238 imp/m ³

The dimensions of the meter are mentioned in *table 3* and in the *figure 3*.

Table 3 - Dimensions of the meter

Nominal diameter DN	A	B	C	E	F
150	598 mm	260 mm	308 mm	336 mm	262 mm

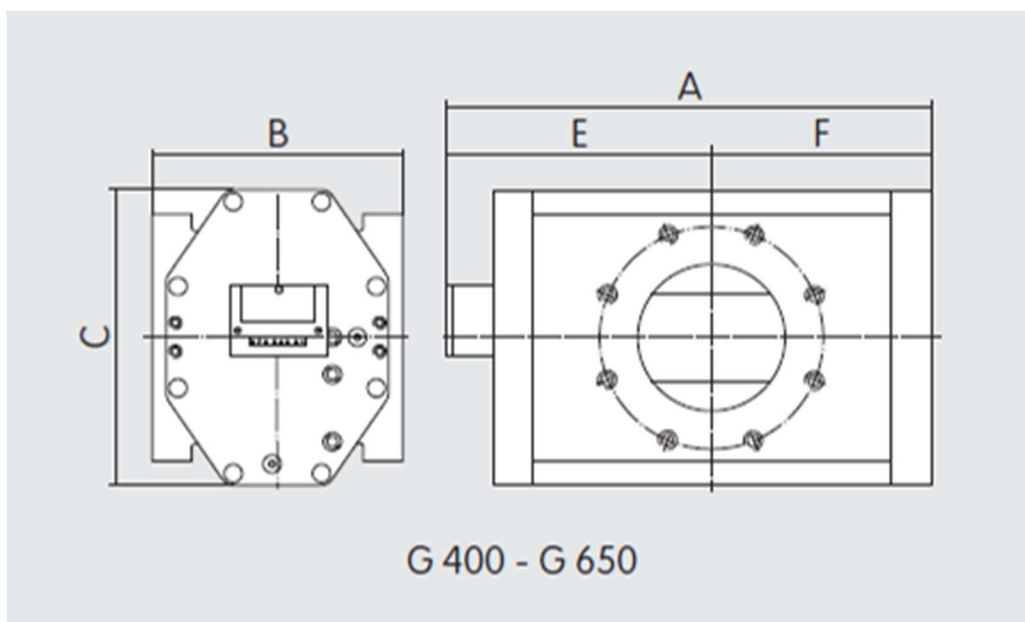

Figure 3 - Dimensions of the meter

The HF pulse generator type REPROX was used. Only one of two HF installed pulse generators was used. The right one was correctly labelled. This emitter is made according to EN 60947-5-6 (NAMUR).

3. Calibration procedure

The rotary piston gas meter G650 was tested with air in the pressure which is close to barometric pressure. The meter was tested in horizontal position in each laboratory. For the tests it was necessary to use the upstream straightening pipe that was long at least 5x DN. The reference pressure from rotary piston gas meter G650 was measured from the output “p_r”. The reference temperature from the rotary piston gas meter was measured in the distance (2÷3) x DN downstream of the rotary piston gas meter.

The pulse emitter REPROX with the pulse number 450.238 imp/m³ was used for the tests. The calibration had to be performed in the laboratory where the temperature was from 19.5°C to 23.5°C. No oil lubrication was used.

The rotary piston gas meter was tested at 9 flow rates:

1000 m³/h, 800 m³/h, 650 m³/h, 450 m³/h, 350 m³/h, 250 m³/h, 160 m³/h, 100 m³/h and 50 m³/h.

The test was repeated at least 3 times in each flow rate and then the means of values in the *table 4* mentioned down were calculated. The flow rate had to be in the interval $\pm 3\%$ of the required value.

Table 4 - Required table of results

Flow rate in the meter	Absolute pressure in the meter	Temperature in the meter	Pressure loss of the meter	Error of the meter	Uncertainty of the error U(k=2)	Institute service code	Declared expanded uncertainty CMC
(m ³ /h)	(Pa)	(°C)	(Pa)	(%)	(%)	-	(%)
1000							
800							
650							
450							
350							
250							
160							
100							
50							

Error of the meter is value which shows the relationship in percentage terms of the difference between the volume indicated by the meter and the volume which has actually flowed through the meter, to the later value.

$$E = \frac{V_i - V_c}{V_c} \cdot 100 \quad (\%) \quad [1]$$

where E is the error of the meter

V_i is the indicated volume by the meter (m³)

V_c is the real volume which has actually flowed through the meter (m³)

4. Test facility and obtained results

4.1. Czech Republic

Place of calibration: Czech Metrology Institute (CMI)
Regional Inspectorate Pardubice, Gas Flow Laboratory
Průmyslová 455, 53003 Pardubice
Czech Republic

The test bench with sonic nozzles consists of 14 nozzles which are situated in 3 blocks. The vacuum is generated by two centrifugal fans and by one vacuum pump. The clamping system of gas meter is pneumatic. There are one barometric pressure meter and six gauge pressure sensors in the test bench.

Three of gauge pressure sensors measure the negative pressures in blocks of nozzles, one of them measures the tightness of lines which are out of operation, one measures the negative pressure in gas meter (p_r) and the last one measures the pressure loss of gas meter.

Five temperature sensors measure the temperature in blocks of nozzles, in the gas meter and in the input of air to the test bench. Besides the humidity in the input of air to the test bench and the time of test are measured, too. A schematic drawing of the test bench is shown in *Figure 4*.

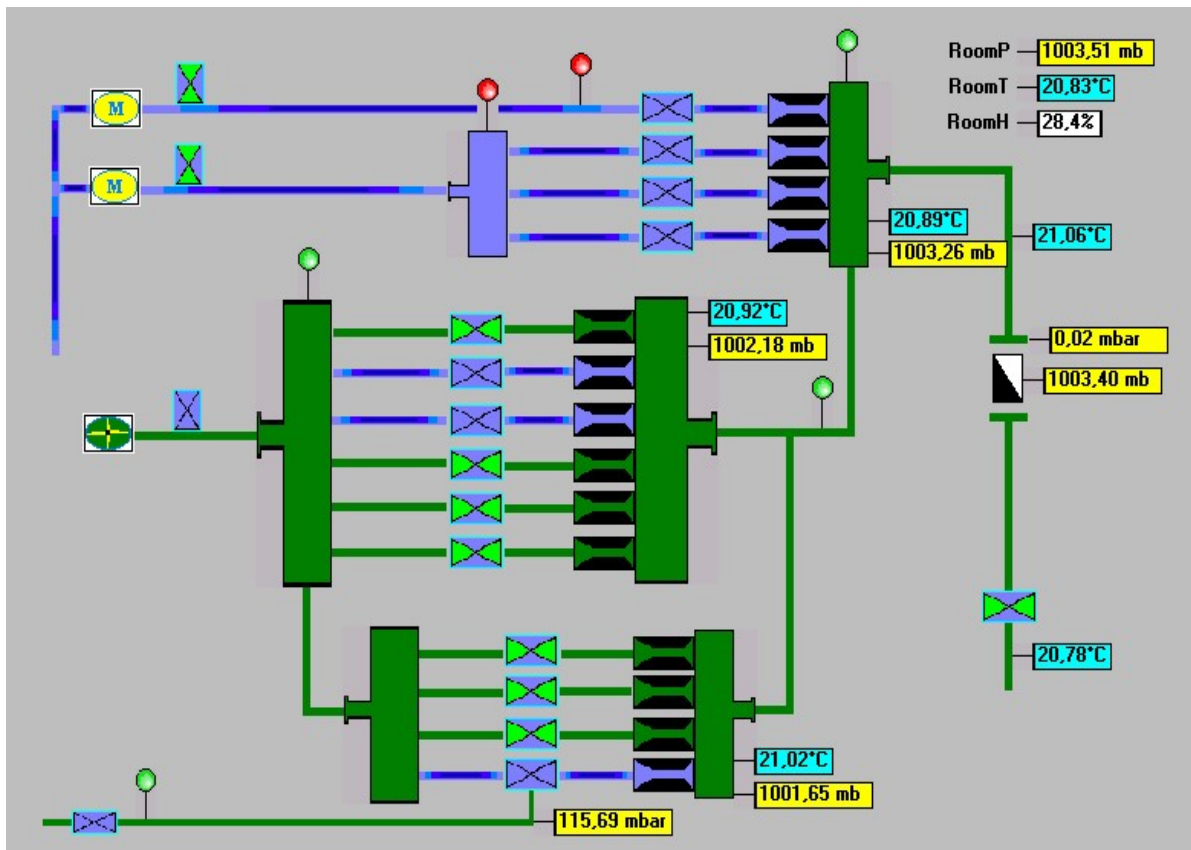

Figure 4 – Test bench with sonic nozzles in CMI

The flow of air reaches the critical status in nozzle and it means the constant mass flow rate of air in nozzle. By combination of different nozzles and by measurements of temperature, pressure and humidity it is possible to ensure the known volume flow rate. The test bench works in the range from 0,06 m³/h till 1200 m³/h.

This test bench is controlled by PC and the one works fully automatically. It is only necessary to clamp the gas meter to the test bench. Then the operator inputs the data of the gas meter and defines the required sequence of the flow rates. The measurement starts with the leakage test. The comparison of all pulse emitters of the gas meter follows. Until these two exams are successful the determination of error of the gas meter in sequence of flow rates does not begin. The measurement runs independently by automatically adjusting of the flow rates.

During the test the temperature in the blocks of nozzles and in the gas meter, the pressure in the blocks of nozzles and in the gas meter and the humidity are measured once per 2 seconds. The time of test is measured, too. The time of test in one flow rate is at least 60 seconds.

The test bench with sonic nozzles was made by *Schlumberger Industries*, Calibration Equipments Division, Barcelona, Spain in 1998. (Now it is *Inotech Spain Meter Calibration Systems, S.L.*) The type designation is SONICAL SN-1000, serial number of the bench is 330.

All sonic nozzles are calibrated by CMI. Standard gas meters with the traceability to *Physikalisch-Technische Bundesanstalt* (PTB) are used for the calibration of the sonic nozzles.

The 6 pieces of temperature sensors Pt100 DESIN, 6 pieces of gauge pressure sensors FEDISA, barometric pressure sensor DRUCK, pulse timer and humidity sensor VAISALA are calibrated regularly with standards that are traceable Czech national standards.

Results of Czech Republic (CMI):

Flow rate in the meter	Absolute pressure in the meter	Temperature in the meter	Pressure loss of the meter	Error of the meter	Uncertainty of the error U(k=2)	Institute service code	Declared expanded uncertainty CMC
(m ³ /h)	(Pa)	(°C)	(Pa)	(%)	(%)	-	
1000	99 673	21.31	825	0.08	0.25	CZ3	0.25
800	99 829	21.35	499	0.15	0.25	CZ3	0.25
650	99 911	21.43	323	0.14	0.25	CZ3	0.25
450	100 015	21.50	107	0.25	0.25	CZ3	0.25
350	100 052	21.53	51	0.27	0.25	CZ3	0.25
250	100 073	21.56	28	0.28	0.25	CZ3	0.25
160	100 083	21.57	13	0.37	0.25	CZ3	0.25
100	100 094	21.58	7	0.32	0.25	CZ3	0.25
50	100 102	21.60	4	0.29	0.25	CZ3	0.25

4.2. Germany

The large gas meter test bench works with critical nozzles as flow sensors. This principle exploits the property of a critical nozzle that the volume flow through the nozzle above a certain (critical) pressure ratio between input and output is only dependent on the speed of sound and the cross-sectional area in the nozzle neck. The flow resulting from the current temperature and inlet pressure ratios at the nozzles is converted to the thermodynamic conditions on the DUT and serves as a reference value for calibration. A schematic drawing and the photo of the test bench is shown in *Figure 5*.

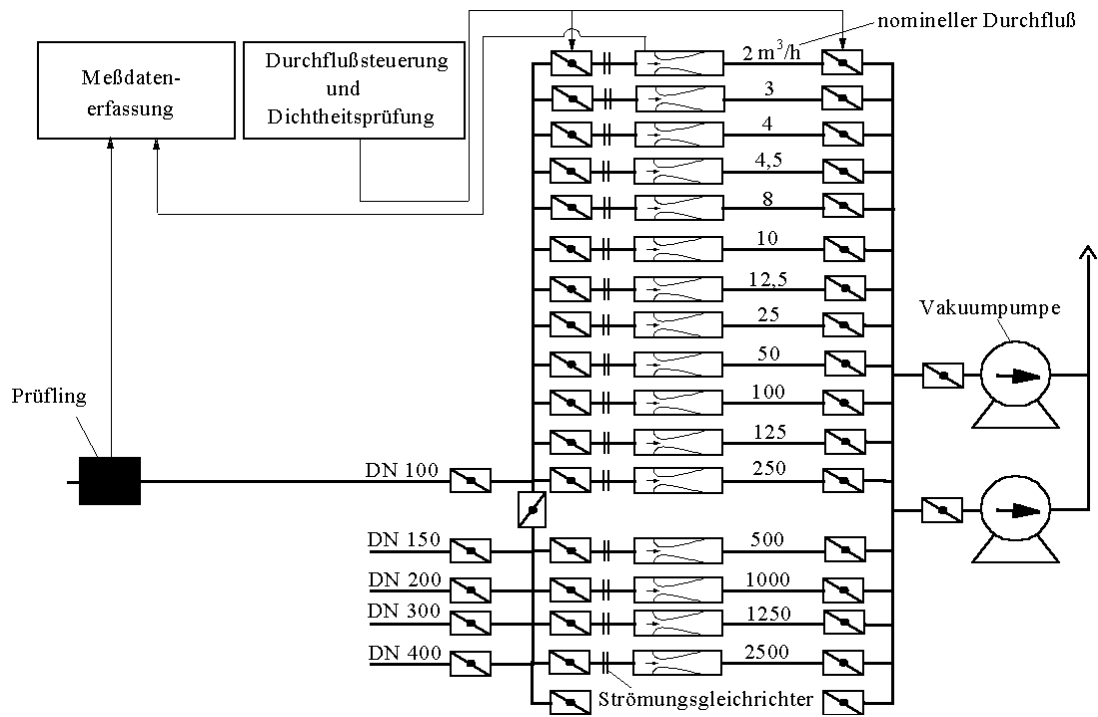

Figure 5 – Test bench in PTB

Results of Germany (PTB):

Flow rate in the meter	Absolute pressure in the meter	Temperature in the meter	Pressure loss of the meter	Error of the meter	Uncertainty of the error U(k=2)	Institute service code	Declared expanded uncertainty CMC
(m ³ /h)	(Pa)	(°C)	(Pa)	(%)	(%)	-	(%)
1000	98796.5	19.91	750.9	0.179	0.081	DE35	0.08
800	99020.1	19.95	471.1	0.187	0.081	DE35	0.08
650	99154.4	19.96	325.4	0.193	0.082	DE35	0.08
450	99256.1	20.02	158.0	0.234	0.081	DE35	0.08
350	99306.4	20.06	98.2	0.265	0.081	DE35	0.08
250	99339.4	20.05	52.1	0.276	0.081	DE35	0.08
160	99398.9	20.06	22.4	0.355	0.081	DE35	0.08
100	99431.9	20.06	10.1	0.376	0.081	DE35	0.08
50	99444.1	20.04	3.6	0.369	0.081	DE35	0.08

4.3. Denmark

Description of the test facilities.

The tests were performed on facility FORCE no. C02-001 [in the flow range (50- 100) m³/h], and C02-004 [in the flow range of (160-1000) m³/h] respectively.

The **C02-001** gas flow meter test facility at FORCE Technology, conducts first time verification, control, and recalibration of volume flow meters using atmospheric air in the flow range of (1-400) m³/h. It consists of three parallel running test lines (containing reference meters / working standards) in series with 1 primary line, where the meter under test is situated. The necessary working standards are permanently placed in their corresponding test lines, which are chosen according to flow requirements.

The working principle of the facility is that of the suction pressure principle, where atmospheric air from the test laboratory is drawn through the meter under test, (which is placed upstream, before the working standards) and later through the test line further downstream, where the working standards are placed. See *Figure 6* below.



Figure 6 – Test bench C2-001 in FORCE Technology

The C02-004 gas flow meter test facility at FORCE technology, conducts first time verification, control, and recalibration of volume flow meters using atmospheric air in the flow range of 65-25000m³/h. The facility consists of five parallel reference lines, and a measuring line in series with these, where the meter under test is located. The facility operates according to the suction pressure principle under atmospheric pressure conditions, where two centrifugal blowers draws air from the calibration room, through the meter under test, and then through the reference strings containing the working standards further downstream. See *Figure 7* below.

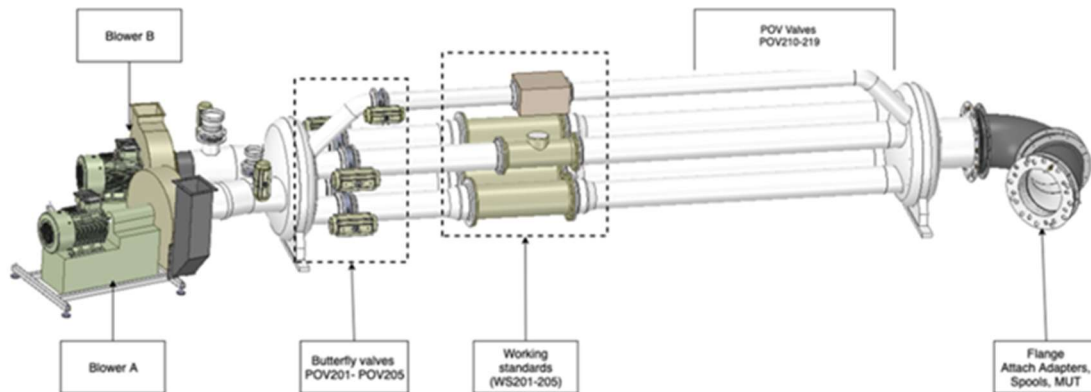

The C02-004 gas flow test facility at Force technology, conducts first time verification, control and recalibration of volume flow meters using atmospheric air in the flow range of 65-25000 m³/h.

Figure 7 – Test bench C2-004 in FORCE Technology

Test description:

During the tests at the two facilities, the meter was mounted before the Working standards upstream. The air is drawn through the meter under test and the Working standards after the initial conditioning according to specified requirements.

The pressure differentials were measured by a differential pressure meter between the meter under test, and the Working standards, and between the meter under test and the barometer reading from the test facility. The pressures were measured at the Pr during the tests, for both the meter and Working meters. The corresponding temperature for the meter under test was measured 2D downstream using a thermistor. The absolute pressure differential across the meter was obtained by two pressure tapings, situated 1D upstream and 1D downstream from the meter, respectively. The pressure measurement was made using a Beamex MC6 – A75030.

Traceability:

The Working standards are traceable to the VSL in Holland, are being recalibrated every second year. The thermistor is traceable to Danish Technological Institute, and the pressure meters are traceable to PTB in Germany.

Uncertainty:

The Uncertainty of the calibration is in accordance with EA-4/02 “Expression of the Uncertainty of Measurement in Calibration”, and is the following for each test facility:



C02-001: (1 – 400) m³/h, $U_{tot} \pm 0.22$ [%], KCDB ID : EURAMET-M-DK-000009J7-3

C02-004: (65 – 25000) m³/h, $U_{tot} \pm 0.23$ [%], KCDB ID : EURAMET-M-DK-00000KBP-1

Results of Denmark (FORCE):

Flow rate in the meter	Absolute pressure in the meter	Temperature in the meter	Pressure loss of the meter	Error of the meter	Uncertainty of the error U(k=2)	Institute service code	Declared expanded uncertainty CMC
(m ³ /h)	(Pa)	(°C)	(Pa)	(%)	(%)		(%)
1000	100172	21.7	859	0.27	0.23	EURAMET-M-DK-00000KBP-1	0.23
800	100270	21.1	562	0.21	0.23	EURAMET-M-DK-00000KBP-1	0.23
650	100312	20.8	368	0.23	0.23	EURAMET-M-DK-00000KBP-1	0.23
450	100328	20.6	183	0.25	0.23	EURAMET-M-DK-00000KBP-1	0.23
350	100305	20.2	108	0.31	0.23	EURAMET-M-DK-00000KBP-1	0.23
250	100265	20.8	58	0.36	0.23	EURAMET-M-DK-00000KBP-1	0.23
160	100232	20.9	26	0.35	0.23	EURAMET-M-DK-00000KBP-1	0.23
100	100203	20.0	12	0.32	0.22	EURAMET-M-DK-000009J7-3	0.22
50	101927	20.1	4	0.26	0.22	EURAMET-M-DK-000009J7-3	0.22

4.4. Netherlands

Results of Netherlands (VSL):

Flow rate in the meter	Absolute pressure in the meter	Temperature in the meter	Pressure loss of the meter	Error of the meter	Uncertainty of the error U(k=2)	Institute service code	Declared expanded uncertainty CMC on
(m ³ /h)	(Pa)	(°C)	(Pa)	(%)	(%)	-	(%)
1000	99501.8	20.01	665	0.14	0.15	VSL/NE05	0.15
800.6	99252.0	20.01	423	0.08	0.16	VSL/NE05	0.15
648.1	99160.6	19.99	279	0.18	0.15	VSL/NE05	0.15
449.0	98992.3	20.01	135	0.20	0.15	VSL/NE05	0.15
348.9	98979.6	19.98	84	0.26	0.15	VSL/NE05	0.15
249.3	98970.9	19.95	46	0.29	0.15	VSL/NE05	0.15
159.5	98930.4	19.96	22	0.31	0.15	VSL/NE05	0.15
99.51	98923.5	19.95	11	0.32	0.15	VSL/NE05	0.15
49.69	98925.5	19.94	12	0.37	0.15	VSL/NE05	0.15

4.5. Austria

Place of calibration:

BEV-Bundesamt für Eich- und Vermessungswesen
Arltgasse 35, 1160 Wien, Austria

Description of the test facilities and the calibration procedure:

Range of flow rate CMC BEV/AT2:	(0.5 to 400) m ³ /h
Range of flow rate CMC BEV/AT3:	(100 to 1000) m ³ /h
CMC (BEV/AT2, BEV/AT3)	0.30 %
Temperature:	(22 ± 1) °C
Working pressure:	atmospheric condition

The testing rig (*Figure 6*) consist of three parallel lines, that can be cut of individually in order to direct the air flow through a standard meter and its dedicated temperature and pressure sensor. The air flow in the rig originates from a pump downstream of the standard meters. The flow rate is coarse adjusted by a valve before the pump and fine adjusted by the rotational speed of the air pump via the control program of the rig. The device under test (DUT) and the reference temperature and pressure sensors are mounted upstream of the standard meters. After the flow is adjusted and stable, the measurement is performed by starting/stopping the data acquisition via the control program. The sensor data and the pulse signals of the meters are read out periodically during the measurement, and the average value of the temperature and the pressure are used to convert the accumulated volume of one standard meter to the reference conditions at the DUT. The control program calculates the error and the measurement uncertainty of the DUT.

The rotary piston gas meter for the comparison was installed with an upstream straightening pipe of length 120 cm. The accumulated volume of the meter was read out via the HF pulse emitter. The reference temperature of the rotary piston gas meter was measured 40 cm downstream of the meter. The reference pressure of the meter was measured at the pressure outlet marked “Pr”. Another pressure sensor was connected to the outlet marked “Pm” for the pressure loss evaluation. The measurement time of a single measurement was above 180 seconds and a measurement point was repeated three time.

Standard Meters

	Meter type	Size	Flow range	Manufacturer
N1	Rotary piston meter (DUO)	G650	6 to 1000 m ³ /h	Instromet
N2	Rotary piston meter (DUO)	G250	1 to 400 m ³ /h	Instromet
N3	Rotary piston meter (DUO)	G40	0,5 to 65 m ³ /h	Instromet

The standard meters are traceable to PTB (Germany) with a recalibration interval of 4 years. The temperature sensors are traceable to BEV with a calibration interval of 2 years. The barometer and the relative pressure sensors are traceable to BEV with a calibration interval of 1 year. The internal clock of the PC is synchronized via an NTP-Server to the atomic clock of BEV.

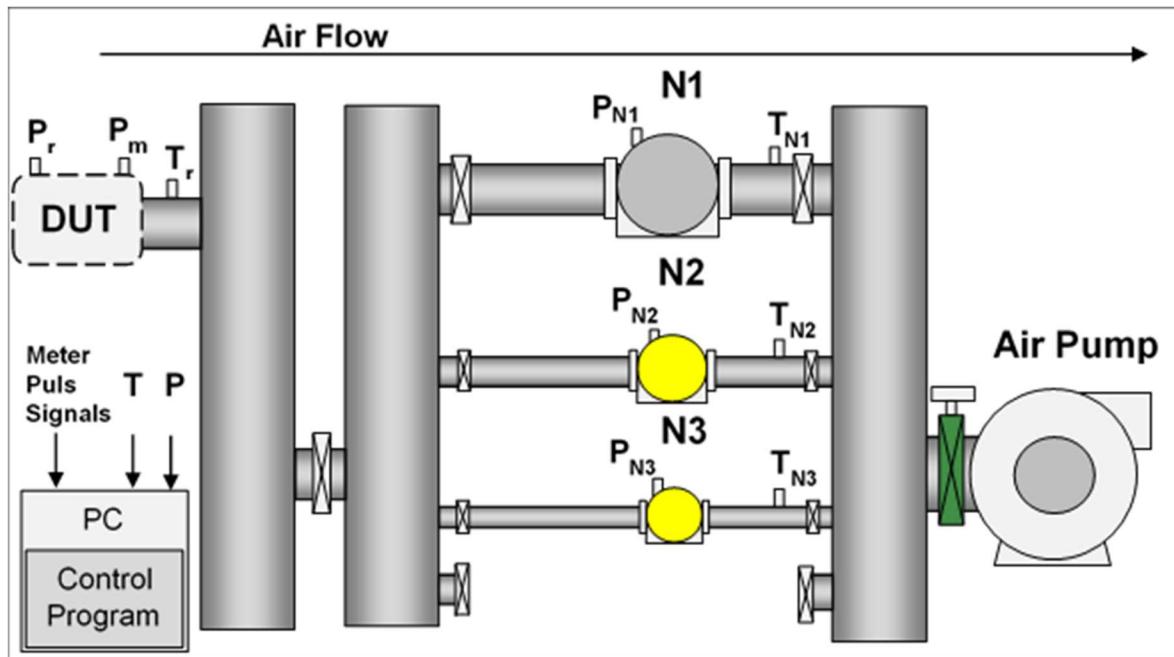

Figure 8 – Test bench in BEV

Results of Austria (BEV):

Flow rate in the meter	Absolute pressure in the meter	Temperature in the meter	Pressure loss of the meter	Error of the meter	Uncertainty of the error $U(k=2)$	Institute service code	Declared expanded uncertainty CMC
(m ³ /h)	(Pa)	(°C)	(Pa)	(%)	(%)	-	(%)
1000	99079	22.0	618	0.06	0.25	BEV/AT3	0.30
800	99225	21.9	420	0.16	0.25	BEV/AT3	0.30
650	99352	21.8	288	0.13	0.25	BEV/AT3	0.30
450	99532	21.9	142	0.20	0.25	BEV/AT3	0.30
350	99049	22.1	87	0.28	0.26	BEV/AT3; BEV/AT2	0.30
250	99093	22.1	47	0.29	0.26	BEV/AT3; BEV/AT2	0.30
160	99108	22.1	21	0.31	0.25	BEV/AT3; BEV/AT2	0.30
100	99099	22.1	9	0.31	0.25	BEV/AT3; BEV/AT2	0.30
50	99053	22.1	4	0.34	0.25	BEV/AT2	0.30

4.6. Poland

Test facility:

Bell prover

Range of flow rate: (9 to 7000) m³/h

Working pressure: atmospheric conditions

Situated: Central Offices of Measures, Flow Laboratory
ul. Elektoralna 2, 00-139 Warsaw, Poland.

CMC in KCDB: 0,26 % - GUM/PL11

Traceability: The standard is related to national standards of length, time, pressure, temperature.

Test procedure: Calibration of a gas meter is carried out by determination of the error-flow rate relationship. Errors of the calibrated gas meter are calculated as a ratio of the difference of the volume measured by the gas meter and the reference volume to the reference volume. The reference volume is determined on the basis of measurement dose of the bell prover and calculated to the conditions of the gas meter. The volume measured by a gas meter is calculated by multiplying number of high frequency pulses by the pulse generator constant.

Results of Poland (GUM):

Flow rate in the meter	Absolute pressure in the meter	Temperature in the meter	Pressure loss of the meter	Error of the meter	Uncertainty of the error U(k=2)	Institute service code	Declared expanded uncertainty CMC
(m ³ /h)	(Pa)	(°C)	(Pa)	(%)	(%)	-	(%)
1000	103511	20.96	–	0.18	0.22	PL11	0.26
800	103608	21.08	–	0.18	0.22	PL11	0.26
650	103591	21.20	–	0.17	0.22	PL11	0.26
450	103644	21.10	–	0.32	0.22	PL11	0.26
350	104552	21.19	–	0.33	0.22	PL11	0.26
250	104678	21.16	–	0.35	0.22	PL11	0.26
160	104785	21.12	–	0.41	0.22	PL11	0.26
100	104896	21.21	–	0.27	0.22	PL11	0.26
50	105101	21.06	–	0.22	0.22	PL11	0.26

4.7. Lithuania

Test facilities

Two facilities situated in Heat-equipment research and testing laboratory of Lithuanian Energy Institute, 3 Breslaujos str., LT-44403 Kaunas, Lithuania were used for calibration of the rotary piston gas meter (hereinafter – transfer meter).

a) Facility with reference meters No. 2E/3 (LT3)

The facility consists of 5 reference meters installed parallel in the pipeline, temperature and pressure measurement, pulse and time calculation and data processing systems.

The main characteristics of the facility: measurement range is (1–9700) m³/h, the calibration and measurement capability in the range of flow rate (2.5–1600) m³/h is $\pm 0,25$ %.

The reference meters parameters are described down:

Reference meter No.	Type	Manufacturer	Range, m ³ /h
1	Rotary meter IRM-A-DUO G100	Instromet	(1–100)
2	Turbine meter AAT-18 G250	Sensus	(50–500)
3	Turbine meter AAT-60 G1000	Equimeter	(160–1600)
4	Turbine meter SM-RI-X-L G4000	Instromet	(320–6500)
5	Turbine meter RP T 95 13 G1000	Common	(160–1600)

The reference meters are all traceable to PTB standards. The recalibration interval of the reference meters is 5 years. The temperature, pressure and time measurement devices are traceable to the Lithuanian national standards.

The general view of the facility is presented at *Figure 9*.



Figure 9 – Test bench in LEI with reference meters

Test method

The transfer meter was calibrated by the method of comparison the meter's readings with readings of a reference meter. The reference volume is recalculated according to the conditions (temperature and pressure) in the transfer meter.

The transfer meter was placed before the reference meter. The air was sucked by centrifugal fan through the transfer meter and then the reference meter.

According to the Technical Protocol for EURAMET Project No. 1590 "Inter-laboratory Calibration Comparison of the Rotary Piston Gas Meter G650" the transfer meter was calibrated at 9 values of flow rate: (1000, 800, 650, 450, 350, 250, 160, 100, 50) m³/h.

Before the beginning of the test the transfer meter worked 20 minutes at flow rate $Q = 400$ m³/h.

Round tubes of diameter DN150 were used as straight pipes. The length of upstream straight pipe was $L_1 = 1.8$ m (12 DN), downstream – $L_2 = 1$ m (6.7 DN).

The thermometer for measurement of the air flow temperature was installed at the distance of 0.4 m (2.7 DN) downstream of the transfer meter.

The reference pressure of the transfer meter has been measured through the output “pr”. The pressure loss of the meter was measured between the output “pr” and the meter outlet.

The deviation of real flow rate values did not exceed $\pm 3\%$ of the required values.

The one single test at one flow rate has taken at least 3 min.

The test at each flow rate was repeated at least 3 times and then the means values were calculated.

b) Facility with sonic nozzles No. 2E/2 (LT2)

The facility consists of 5 sonic nozzles installed parallel in the pipeline and temperature, pressure and humidity measurement, pulse and time calculation and data processing systems.

The main characteristics of the facility: measurement range is (5.7–308.8) m³/h, the calibration and measurement capability is $\pm 0.16\%$.

The nozzles are all traceable to PTB standards. The temperature, pressure, humidity and time measurement devices are traceable to the Lithuanian national standards.

The nozzles parameters are described down:

Nozzle No.	Manufacturer	Nominal flow rate, m ³ /h
1	American Meter Company	5.7
2		22.3
3		50.7
4		89.8
5		141.1

The general view of the facility with sonic nozzles is presented at *Figure 10*.



Figure 10 – Test bench in LEI with sonic nozzles

Test method

The transfer meter was calibrated by the method of comparison the transfer meter readings with volume flow rate, which, after estimating time, is converted into volume produced by critical nozzles. The reference volume is recalculated according to the conditions (temperature and pressure) in the transfer meter. By combining the nozzles we can achieve the required air flow.

The transfer meter was calibrated at 4 values of flow rate: (250, 160, 100, 50) m³/h. Before the beginning of the test the gas meter worked 20 minutes at flow rate Q = 400 m³/h. Round tubes of diameter DN150 were used as straight pipes. The length of upstream straight pipe was L₁ = 0,72 m (4.8 DN), downstream – L₂ = 1 m (6.7 DN).

The thermometer for measurement of the air flow temperature was installed at the distance of 0.4 m (2.7 DN) downstream of the transfer meter. The reference pressure of the rotary piston gas meter has been measured through the output “pr”. The pressure loss of the meter was measured between the output “pr” and the meter outlet. The deviation of real flow rate values did not exceed ± 3%, except one flow rate – 100 m³/h where (due to the setup of nozzles) the flow rate was 94.8 m³/h (deviation - 5.2 %).

The one single test in one flow rate has taken at least 3 min.

The test at each flow rate was repeated at least 3 times and then the means values were calculated.

Results of Lithuania (LEI):

Flow rate in the meter	Absolute pressure in the meter	Temperature in the meter	Pressure loss of the meter	Error of the meter	Uncertainty of the error U(k=2)	Institute service code	Declared expanded uncertainty CMC on
(m ³ /h)	(Pa)	(°C)	(Pa)	(%)	(%)	-	(%)
1000	99577	20.72	711	0.16	0.25	LT3	0.25
800	99717	20.69	459	0.11	0.25	LT3	0.25
650	99809	20.59	301	0.22	0.25	LT3	0.25
450	99905	20.60	148	0.20	0.25	LT3	0.25
350	99928	20.75	90	0.27	0.25	LT3	0.25
250	99954	20.79	48	0.30	0.25	LT3	0.25
160	99540	20.62	22	0.33	0.25	LT3	0.25
100	99551	20.60	9	0.37	0.25	LT3	0.25
50	99571	20.55	3	0.34	0.25	LT3	0.25

Flow rate in the meter	Absolute pressure in the meter	Temperature in the meter	Pressure loss of the meter	Error of the meter	Uncertainty of the error U(k=2)	Institute service code	Declared expanded uncertainty CMC on
(m ³ /h)	(Pa)	(°C)	(Pa)	(%)	(%)	-	(%)
250	101069	19.94	47	0.33	0.16	LT2	0.16
160	101134	19.94	22	0.34	0.16	LT2	0.16
100	101031	19.70	8	0.37	0.16	LT2	0.16
50	101053	19.74	3	0.34	0.16	LT2	0.16

4.8. Sweden

The tests were performed at the RISE Research Institutes of Sweden in Borås (*Figure 11*). The method for gas flow calibrations utilizes reference flow meters, Laminar Flow Elements (LFE) for low flow rates (in order of 1 mL/min – 600 L/min) and flanged nozzles for larger flow rates (in order of 40 m³/h – 8000 m³/h). For the larger flow rates, a variable-speed suction fan is used to drive the flow through the flow meter under test followed by the reference flow meter. Thus, calibrations are limited to ambient conditions regarding temperature and pressure. The LFE reference flow meters are traceable to NIST and the nozzle flow meters are traceable to NEL. The uncertainty of the calibration method, in accordance with EA-4/02, is 0,9 % for the LFE standards and 1,4 % for the nozzle standards.



Figure 11 – Test bench in RISE

Results of Sweden (RISE):

Flow rate in the meter	Absolute pressure in the meter	Temperature in the meter	Pressure loss of the meter	Error of the meter	Uncertainty of the error U(k=2)	Institute service code	Declared expanded uncertainty CMC
(m ³ /h)	(Pa)	(°C)	(Pa)	(%)	(%)	-	(%)
1000	99677	23.5	713	0.08	1.4	-	no CMC
800	99828	23.4	456	0.23	1.4	-	no CMC
650	99919	23.3	306	0.33	1.4	-	no CMC
450	100010	23.1	148	0.04	1.4	-	no CMC
350	100004	23.6	93	0.01	1.4	-	no CMC
250	100022	23.6	48	0.30	1.4	-	no CMC
160	99659	23.7	21	0.72	1.4	-	no CMC
100	99676	23.6	9	0.13	1.4	-	no CMC
50	99655	23.9	4	-0.17	1.4	-	no CMC

4.9. Switzerland

Test facility:

Turbine meter test rig (secondary)

Range in flow: (0.5 to 4500) m³/h

Working pressure: Atmospheric conditions

Location: Federal Institute of Metrology, METAS, Laboratory for Flow

Traceability: METAS bell prover (5135-CH7)

The test rig consists of 6 parallel lines, each equipped with a reference meter traceable to the METAS bell prover. Air flow is generated by sucking laboratory air using blowers first through the device under test and then the reference meters. Volume air flow is converted to mass flow using air pressure, air temperature and air relative humidity and calculated back to volume flow through the device under test using the measured air parameters at the device under test. Air flow is adjusted by a valve. Measurements are performed in flying start-stop mode.

Results of Switzerland (METAS):

Flow rate in the meter	Absolute pressure in the meter	Temperature in the meter	Pressure loss of the meter	Error of the meter	Uncertainty of the error U(k=2)	Institute service code	Declared expanded uncertainty CMC
(m ³ /h)	(Pa)	(°C)	(Pa)	(%)	(%)	-	(%)
1001.4	94751.2	21.8	683.9	0.15	0.16	5135-CH10	0.16
803.0	94877.9	21.8	442.7	0.12	0.16	5135-CH10	0.16
649.8	94953.6	21.8	290.1	0.10	0.16	5135-CH10	0.16
450.1	95029.8	21.7	142.5	0.16	0.16	5135-CH10	0.16
348.9	95059.3	21.7	86.8	0.18	0.16	5135-CH10	0.16
250.2	95080.7	21.7	47.1	0.24	0.16	5135-CH10	0.16
160.9	95088.7	21.7	20.7	0.24	0.16	5135-CH10	0.16
100.8	95083.4	21.7	9.6	0.19	0.16	5135-CH10	0.16
49.9	95057.7	21.7	3.1	0.17	0.16	5135-CH10	0.16

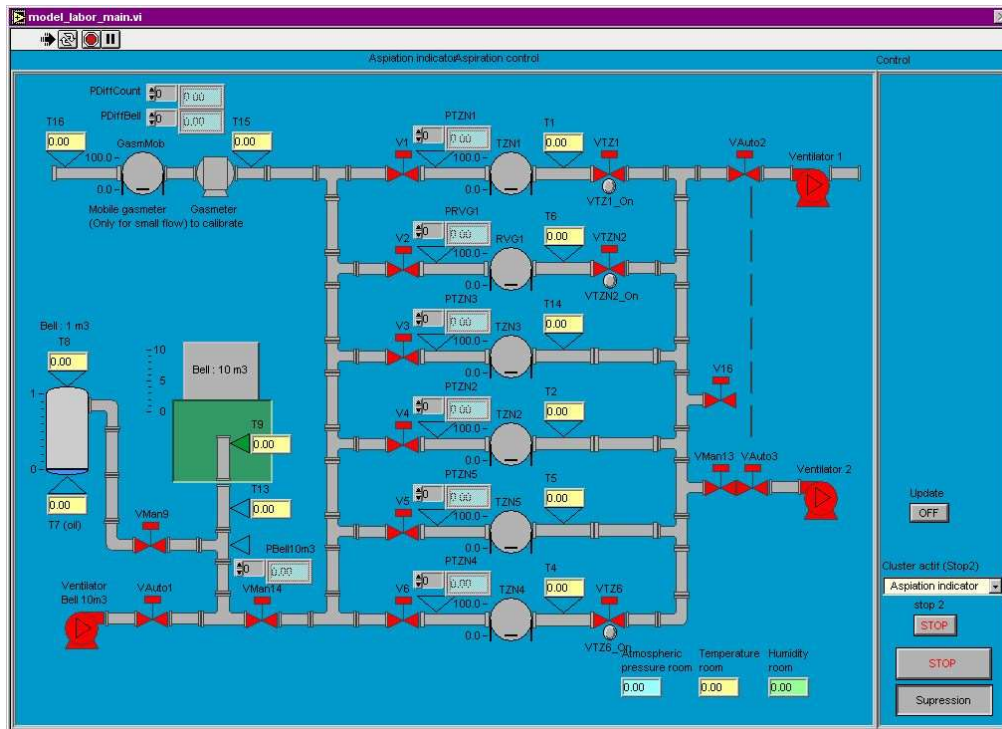

Figure 12 – Test bench in METAS

5. Stability of the meter and the dependency of laboratories

During the project the rotary piston gas meter was tested three times in the pilot laboratory (CMI). Obtained results are mentioned down.

Table 5 – Stability of the rotary piston gas meter G650

flow rate (m ³ /h)	error of the meter at the beginning of the project	error of the meter before sending to Switzerland	error of the meter at the end of the project	maximum difference
(m ³ /h)	(%)	(%)	(%)	(%)
1000	0.08	0.08	0.08	0.00
800	0.16	0.15	0.15	0.01
650	0.14	0.13	0.14	0.01
450	0.24	0.24	0.25	0.01
350	0.26	0.25	0.27	0.02
250	0.25	0.25	0.28	0.03
160	0.35	0.35	0.37	0.02
100	0.30	0.30	0.32	0.02

The estimated standard uncertainty caused by the stability (reproducibility) of the rotary piston gas meter is approximately $u_{tm}=0.0173\%$. In this case the uniform distribution between minimal value and maximal value is assumed. The maximum value of the "maximum difference" was 0.03% and this was divided by the square root of 3.

In this project there was 5 independent laboratory:

Germany, Netherlands, Poland, Switzerland, Sweden

(Sweden is traceable to NIST and NEL but here it was considered to be independent for the evaluation.)

In this project there was 1 laboratory traceable to Netherlands (VSL):

Denmark

In this project there were 3 laboratories traceable to Germany (PTB):

Czech Republic, Austria, Lithuania

6. Determination of the reference values in determined flow rates

The reference value was determined in each flow rate separately. The method of determination of the reference value in each flow rate corresponds to the procedure A presented by M.G.Cox³⁾. Only results from independent laboratories were taken into account for the determination of the key comparison reference value (KCRV) and of the uncertainty of the key comparison reference value. Then the results from dependent laboratories were compared with the key comparison reference value and with the uncertainty of the key comparison reference value.

6.1. The determination of the Key Comparison Reference Value (KCRV) and its uncertainty

The reference value y was calculated as weighted mean error (WME):

$$y = \frac{\frac{x_1}{u_{x1}^2} + \frac{x_2}{u_{x2}^2} + \dots + \frac{x_n}{u_{xn}^2}}{\frac{1}{u_{x1}^2} + \frac{1}{u_{x2}^2} + \dots + \frac{1}{u_{xn}^2}}, \quad [2]$$

where x_1, x_2, \dots, x_n are errors of the meter in one flow rate in different independent laboratories $1, 2, \dots, n$
 $u_{x1}, u_{x2}, \dots, u_{xn}$ are standard uncertainties (not expanded) of the error in different independent laboratories $1, 2, \dots, n$ including the uncertainty caused by stability of the meter

The standard uncertainties (not expanded) of the error in different laboratories $u_{x1}, u_{x2}, \dots, u_{xn}$ (equation [2]) include the stability of the meter. These uncertainties were calculated by

³⁾ Cox M.G., *Evaluation of key comparison data*, Metrologia, 2002, **39**, 589-595

$$u_{xi} = \sqrt{\left(\frac{U_{xi_lab}}{2}\right)^2 + (u_{im})^2} \quad [3]$$

where U_{xi_lab} is the expanded uncertainty (k=2) determined by laboratory i and presented in results of laboratory i

u_{im} is estimated standard uncertainty caused by the stability (reproducibility) of the rotary piston gas meter (see chapter 5)

The standard uncertainty of the reference value u_y is given by

$$\frac{1}{u_y^2} = \frac{1}{u_{x1}^2} + \frac{1}{u_{x2}^2} + \dots + \frac{1}{u_{xn}^2} \quad [4]$$

The expanded uncertainty of the reference value $U(y)$ is

$$U(y) = 2 \cdot u_y \quad [5]$$

The chi-squared test for consistency check was performed using values of errors of the meter in each flow rate. At first the chi-squared value χ_{obs}^2 was calculated by

$$\chi_{obs}^2 = \frac{(x_1 - y)^2}{u_{x1}^2} + \frac{(x_2 - y)^2}{u_{x2}^2} + \dots + \frac{(x_n - y)^2}{u_{xn}^2} \quad [6]$$

The degrees of freedom ν were assigned

$$\nu = n - 1 \quad [7]$$

where n is number of evaluated laboratories.

The consistency check was failing if

$$Pr\{\chi_{\nu}^2 > \chi_{obs}^2\} < 0,05 \quad [8]$$

(The function $CHIINV(0,05; \nu)$ in MS Excel was used. The consistency check was failing if $CHIINV(0,05; \nu) < \chi_{obs}^2$)

If the consistency check did not fail then y was accepted as the key comparison reference value x_{ref} and $U(y)$ was accepted as the expanded uncertainty of the key comparison reference value $U(x_{ref})$.

If the consistency check failed then the laboratory with the highest value of $\frac{(x_i - y)^2}{u_{xi}^2}$ was excluded

for the next round of evaluation and the new reference value y (WME), the new standard uncertainty of the reference value u_y and the chi-squared value χ_{obs}^2 were calculated again without the values of excluded laboratory. The consistency check was calculated again, too. This procedure was repeated till the consistency check passed.

6.2. The determination of the differences “Lab to KCRV” as well as their uncertainties and Degrees of Equivalence

When the KCRV was determined, the differences between the participating laboratories and the KCRV were calculated according to

$$di = x_i - x_{ref} \quad [9]$$

Based on these differences, the Degree of Equivalence (*DoE*) was calculated according to:

$$Ei = \left| \frac{di}{U(di)} \right| \quad [10]$$

The *DoE* is a measure for the equivalence of the results of any laboratory with the KCRV or with any other laboratory, respectively:

- The results of a laboratory is **equivalent (passed)** if $Ei \leq 1$.
- The laboratory was determined as **not equivalent (failed)** if $Ei > 1.2$.
- For values of *DoE* in the range $1 < Ei \leq 1.2$ we define “**warning level**” were actions to check is recommended to the laboratory.

The reason for such “warning level” is that we have to consider the confidence in the determination of the uncertainties (for the results of labs as well the KCRV). Conventionally we work at a 95% confidence level. Therefore in some comparisons a range up to $E < 1.5$ is used for these “warnings”⁴⁴⁾. This is a reasonable value where stochastic influences dominate the uncertainty budgets. In the case of comparisons for gas flow, the smaller value 1.2 was chosen, which reflects the dominance of non-stochastic parts of uncertainty compared to the stochastic parts. (The reproducibility is usually much better than the total uncertainty of a laboratory).⁵⁾

7. Results

The chi-squared test for consistency check was successful right at the beginning and therefore no outliers were found. The KCRV for each flow rate and the uncertainty of the KCRV were calculated from five independent laboratories (Germany, Netherlands, Poland, Switzerland, Sweden). The results are shown below

⁴⁾ C. Ullner et al., *Special features in proficiency tests of mechanical testing laboratories*, and P. Robouch et al., *The „Naji Plot“, a simple graphical tool for the evaluation of inter-laboratory comparisons*,

Both in: D. Richter, W. Wöger, W. Hässelbarth (ed.) *Data analysis of key comparisons*, 178. PTB-Seminar/International Workshop, ISBN 3-89701-933-3.

⁵⁾ D.Dopheide, B.Mickan, R.Kramer, H.-J.Hotze, J.-P.Vallet, M.R.Harris, Jiunn-Haur Shaw, Kyung-Am Park, *CIPM Key Comparisons for Compressed Air and Nitrogen, CCM.FF-5.b – Final Report*, 07/09/2006
<https://is.gd/zuWU8d>

flow rate Q	KCRV error of gas meter	uncertainty of KCRV u_KCRV (k=1)
m ³ /h	%	%
1000	0.168	0.032
800	0.159	0.032
650	0.174	0.032
450	0.224	0.032
350	0.255	0.032
250	0.280	0.032
160	0.335	0.032
100	0.328	0.032
50	0.325	0.032

7.1. Czech Republic - Dependent laboratory (to PTB)

flow rate in the meter	error of the meter in laboratory	uncertainty of the error $U(k=2)$	actual uncertainty declared in CMC $U(k=2)$	uncertainty of the error including stability of the meter $U(k=2)$	key reference value x_{ref}	expanded uncertainty of the key reference value $U(x_{ref})$	di	Ei	result
m ³ /h	%	%	%	%	%	%	%		
1000	0.08	0.25	0.25	0.251	0.168	0.063	-0.11	0.45	passed
800	0.15	0.25	0.25	0.251	0.159	0.064	0.00	0.01	passed
650	0.14	0.25	0.25	0.251	0.174	0.064	-0.04	0.18	passed
450	0.25	0.25	0.25	0.251	0.224	0.063	-0.02	0.10	passed
350	0.27	0.25	0.25	0.251	0.255	0.063	0.02	0.10	passed
250	0.28	0.25	0.25	0.251	0.280	0.063	0.01	0.04	passed
160	0.37	0.25	0.25	0.251	0.335	0.063	-0.03	0.10	passed
100	0.32	0.25	0.25	0.251	0.328	0.063	-0.02	0.08	passed
50	0.29	0.25	0.25	0.251	0.325	0.063	0.02	0.06	passed
mean							-0.02	0.12	passed

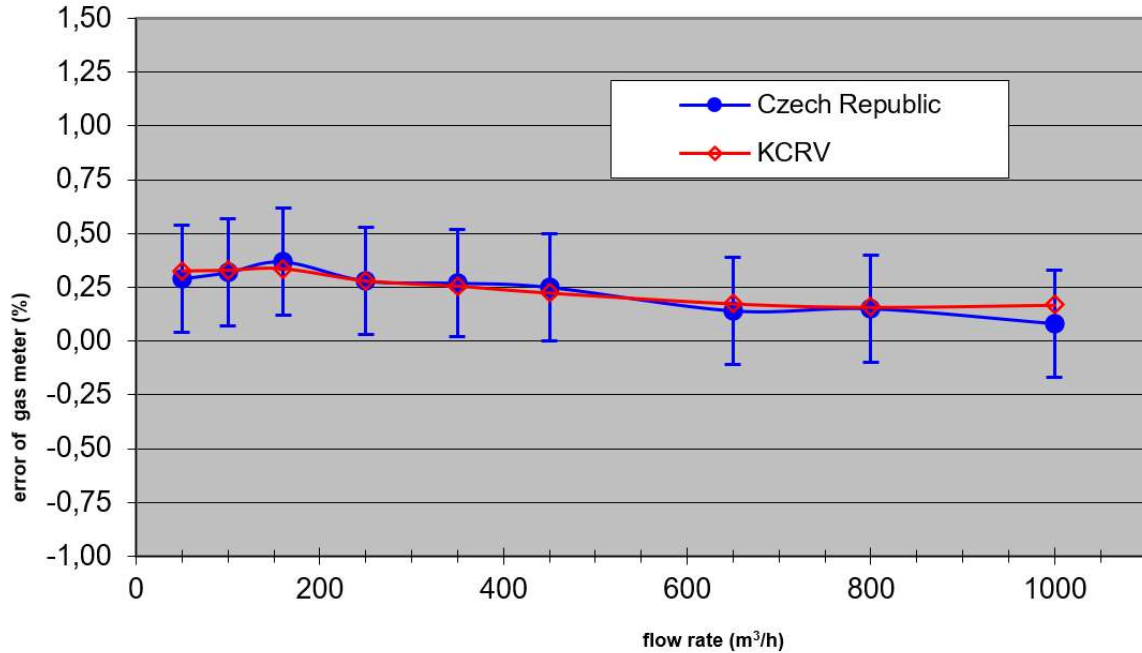

7.2. Germany - Independent laboratory

flow rate in the meter	error of the meter in laboratory	uncertainty of the error $U(k=2)$	actual uncertainty declared in CMC $U(k=2)$	uncertainty of the error including stability of the meter $U(k=2)$	key reference value x_{ref}	expanded uncertainty of the key reference value $U(x_{ref})$	di	Ei	result
m ³ /h	%	%	%	%	%	%	%		
1000	0.179	0.081	0.080	0.0828	0.168	0.063	0.011	0.20	passed
800	0.187	0.081	0.080	0.0828	0.159	0.064	0.028	0.54	passed
650	0.193	0.082	0.080	0.0838	0.174	0.064	0.019	0.34	passed
450	0.234	0.081	0.080	0.0828	0.224	0.063	0.010	0.19	passed
350	0.265	0.081	0.080	0.0828	0.255	0.063	0.010	0.18	passed
250	0.276	0.081	0.080	0.0828	0.280	0.063	-0.004	0.07	passed
160	0.355	0.081	0.080	0.0828	0.335	0.063	0.020	0.37	passed
100	0.376	0.081	0.080	0.0828	0.328	0.063	0.048	0.90	passed
50	0.369	0.081	0.080	0.0828	0.325	0.063	0.044	0.83	passed
mean							0.021	0.40	passed

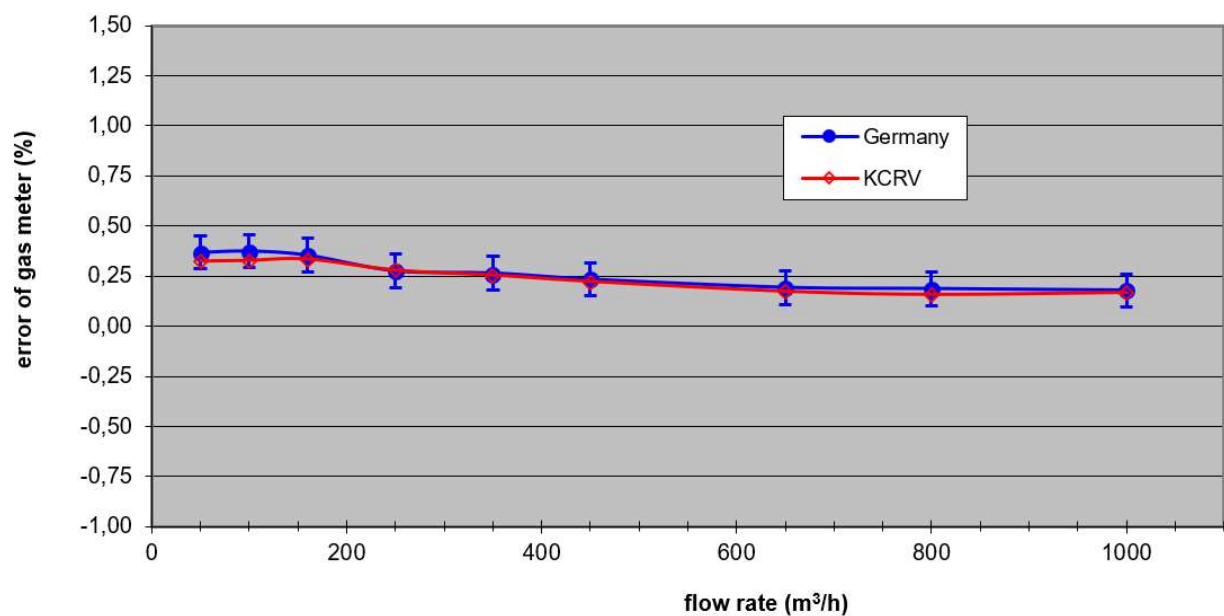

7.3. Denmark - Dependent laboratory (traceable to VSL)

flow rate in the meter	error of the meter in laboratory	uncertainty of the error $U(k=2)$	actual uncertainty declared in CMC $U(k=2)$	uncertainty of the error including stability of the meter $U(k=2)$	key reference value x_{ref}	expanded uncertainty of the key reference value $U(x_{ref})$	di	Ei	result
m ³ /h	%	%	%	%	%	%	%		
1000	0.27	0.23	0.23	0.2307	0.168	0.063	0.10	0.53	passed
800	0.21	0.23	0.23	0.2307	0.159	0.064	0.05	0.27	passed
650	0.23	0.23	0.23	0.2307	0.174	0.064	0.06	0.29	passed
450	0.25	0.23	0.23	0.2307	0.224	0.063	0.03	0.14	passed
350	0.31	0.23	0.23	0.2307	0.255	0.063	0.05	0.24	passed
250	0.36	0.23	0.23	0.2307	0.280	0.063	0.08	0.35	passed
160	0.35	0.23	0.23	0.2307	0.335	0.063	0.01	0.06	passed
100	0.32	0.22	0.22	0.2207	0.328	0.063	-0.01	0.04	passed
50	0.26	0.22	0.22	0.2207	0.325	0.063	-0.06	0.29	passed
mean							0.03	0.24	passed

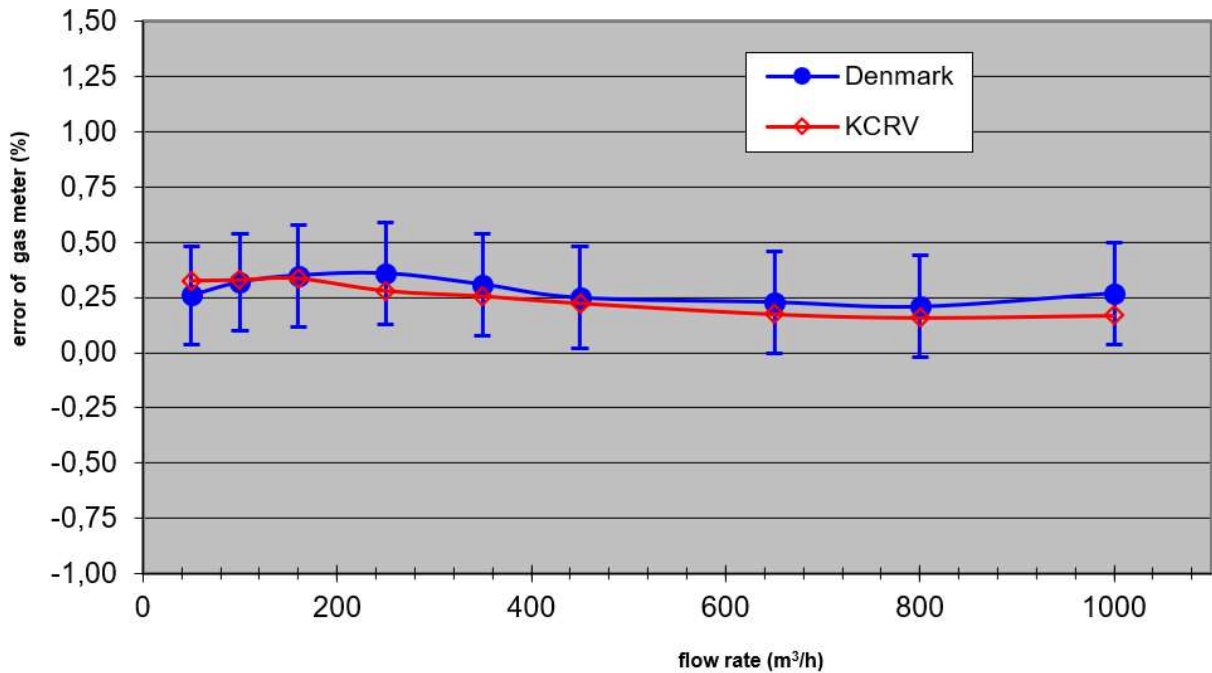

7.4. Netherlands - Independent laboratory

flow rate in the meter	error of the meter in laboratory	uncertainty of the error $U(k=2)$	actual uncertainty declared in CMC $U(k=2)$	uncertainty of the error including stability of the meter $U(k=2)$	key reference value x_{ref}	expanded uncertainty of the key reference value $U(x_{ref})$	di	Ei	result
m ³ /h	%	%	%	%	%	%	%		
1000	0.14	0.15	0.15	0.1510	0.168	0.063	-0.03	0.21	passed
800	0.08	0.16	0.15	0.1609	0.159	0.064	-0.08	0.53	passed
650	0.18	0.15	0.15	0.1510	0.174	0.064	0.01	0.04	passed
450	0.20	0.15	0.15	0.1510	0.224	0.063	-0.02	0.17	passed
350	0.26	0.15	0.15	0.1510	0.255	0.063	0.00	0.04	passed
250	0.29	0.15	0.15	0.1510	0.280	0.063	0.01	0.08	passed
160	0.31	0.15	0.15	0.1510	0.335	0.063	-0.03	0.18	passed
100	0.32	0.15	0.15	0.1510	0.328	0.063	-0.01	0.06	passed
50	0.37	0.15	0.15	0.1510	0.325	0.063	0.05	0.33	passed
mean							-0.01	0.18	passed

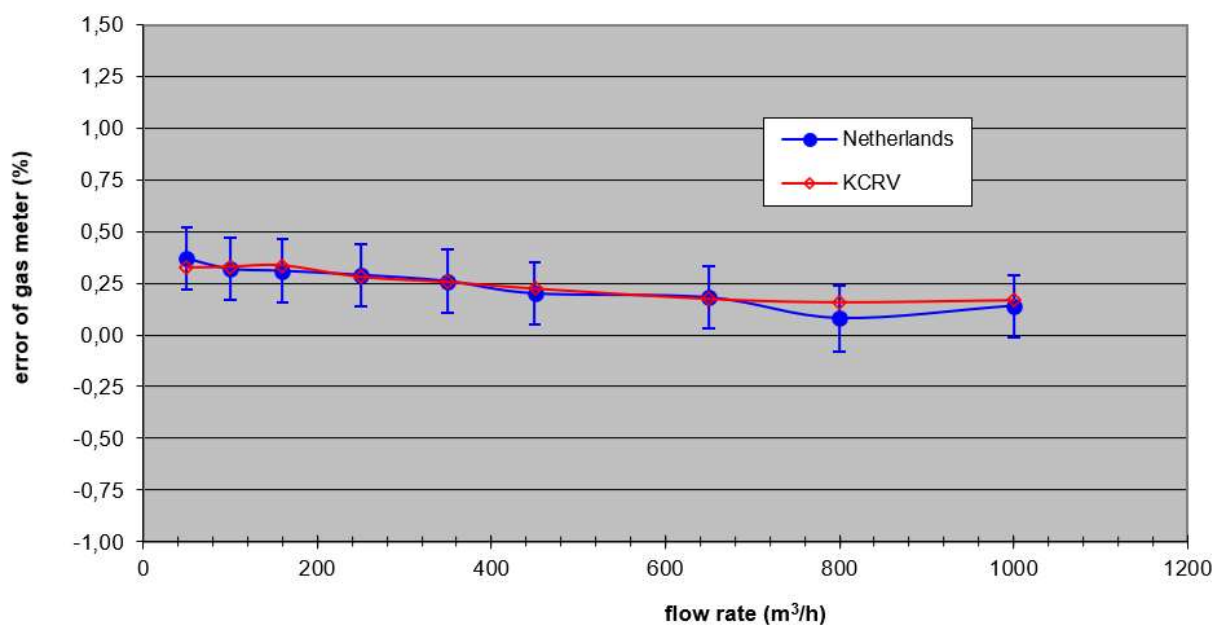

7.5. Austria - Dependent laboratory (traceable to PTB)

flow rate in the meter	error of the meter in laboratory	uncertainty of the error $U(k=2)$	actual uncertainty declared in CMC $U(k=2)$	uncertainty of the error including stability of the meter $U(k=2)$	key reference value x_{ref}	expanded uncertainty of the key reference value $U(x_{ref})$	di	Ei	result
m ³ /h	%	%	%	%	%	%	%		
1000	0.06	0.25	0.30	0.2506	0.168	0.063	-0.11	0.45	passed
800	0.16	0.25	0.30	0.2506	0.159	0.064	0.00	0.01	passed
650	0.13	0.25	0.30	0.2506	0.174	0.064	-0.04	0.18	passed
450	0.20	0.25	0.30	0.2506	0.224	0.063	-0.02	0.10	passed
350	0.28	0.26	0.30	0.2606	0.255	0.063	0.02	0.10	passed
250	0.29	0.26	0.30	0.2606	0.280	0.063	0.01	0.04	passed
160	0.31	0.25	0.30	0.2506	0.335	0.063	-0.03	0.10	passed
100	0.31	0.25	0.30	0.2506	0.328	0.063	-0.02	0.08	passed
50	0.34	0.25	0.30	0.2506	0.325	0.063	0.02	0.06	passed
mean							-0.02	0.12	passed

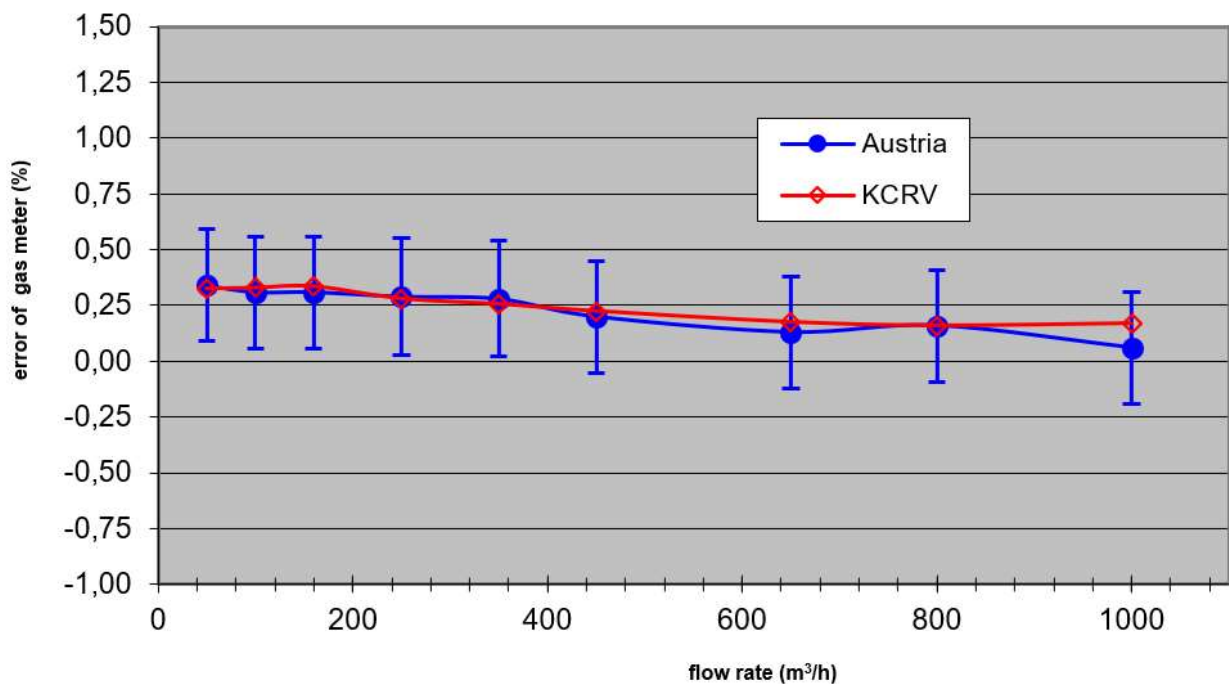

7.6. Poland - Independent laboratory

flow rate in the meter	error of the meter in laboratory	uncertainty of the error $U(k=2)$	actual uncertainty declared in CMC $U(k=2)$	uncertainty of the error including stability of the meter $U(k=2)$	key reference value x_{ref}	expanded uncertainty of the key reference value $U(x_{ref})$	di	Ei	result
m ³ /h	%	%	%	%	%	%	%		
1000	0.18	0.22	0.26	0.2207	0.168	0.063	0.01	0.06	passed
800	0.18	0.22	0.26	0.2207	0.159	0.064	0.02	0.10	passed
650	0.17	0.22	0.26	0.2207	0.174	0.064	0.00	0.02	passed
450	0.32	0.22	0.26	0.2207	0.224	0.063	0.10	0.46	passed
350	0.33	0.22	0.26	0.2207	0.255	0.063	0.07	0.35	passed
250	0.35	0.22	0.26	0.2207	0.280	0.063	0.07	0.33	passed
160	0.41	0.22	0.26	0.2207	0.335	0.063	0.07	0.35	passed
100	0.27	0.22	0.26	0.2207	0.328	0.063	-0.06	0.28	passed
50	0.22	0.22	0.26	0.2207	0.325	0.063	-0.10	0.50	passed
mean							0.02	0.27	passed

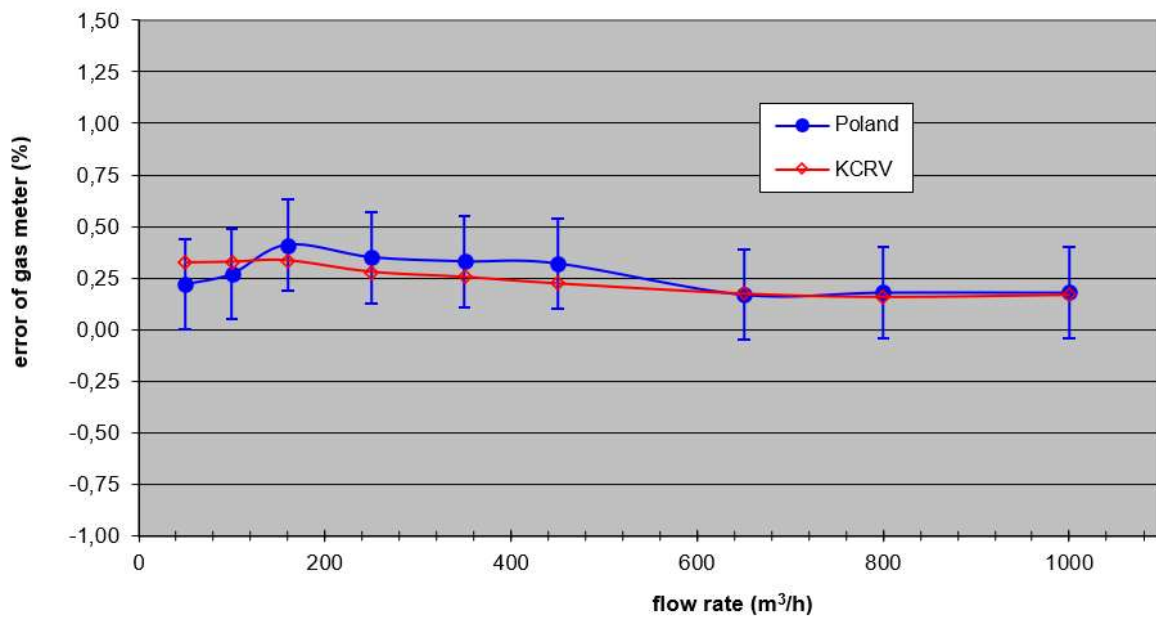

7.7. Lithuania - Dependent laboratory (traceable to PTB)

flow rate in the meter	error of the meter in laboratory	uncertainty of the error $U(k=2)$	actual uncertainty declared in CMC $U(k=2)$	uncertainty of the error including stability of the meter $U(k=2)$	key reference value x_{ref}	expanded uncertainty of the key reference value $U(x_{ref})$	d_i	E_i	result
m^3/h	%	%	%	%	%	%	%		
1000	0.16	0.25	0.25	0.2506	0.168	0.063	-0.01	0.03	passed
800	0.11	0.25	0.25	0.2506	0.159	0.064	-0.05	0.20	passed
650	0.22	0.25	0.25	0.2506	0.174	0.064	0.05	0.19	passed
450	0.20	0.25	0.25	0.2506	0.224	0.063	-0.02	0.10	passed
350	0.27	0.25	0.25	0.2506	0.255	0.063	0.01	0.06	passed
250	0.33	0.16	0.16	0.1609	0.280	0.063	0.05	0.34	passed
160	0.34	0.16	0.16	0.1609	0.335	0.063	0.00	0.03	passed
100	0.37	0.16	0.16	0.1609	0.328	0.063	0.04	0.28	passed
50	0.34	0.16	0.16	0.1609	0.325	0.063	0.02	0.10	passed
mean							0.01	0.15	passed

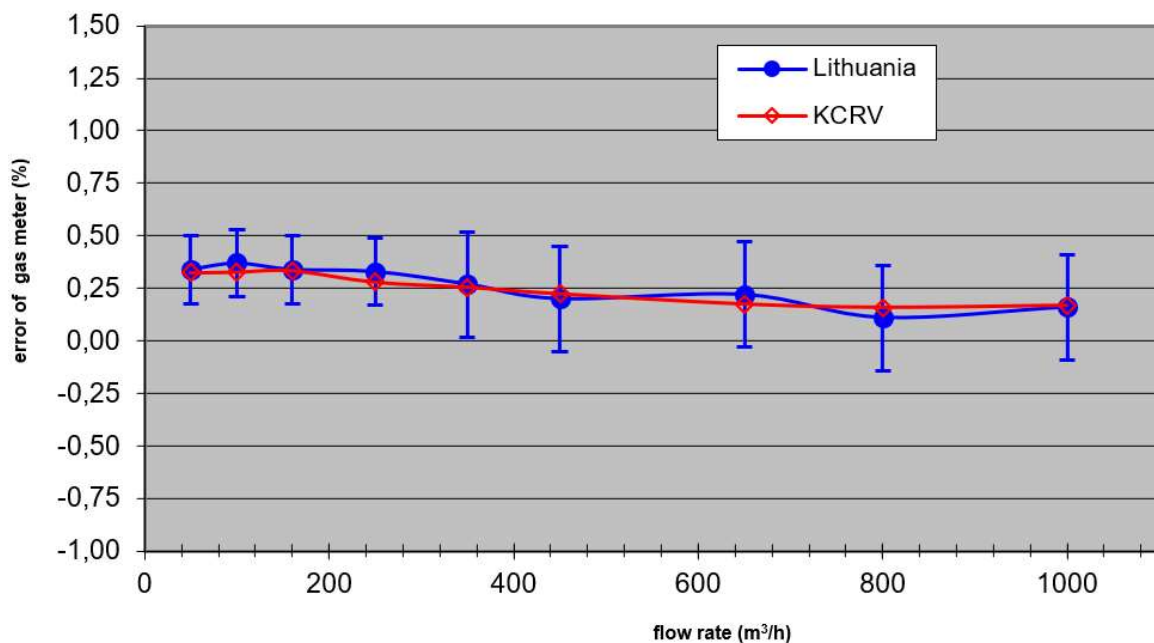

7.8. Sweden - Independent laboratory

flow rate in the meter	error of the meter in laboratory	uncertainty of the error $U(k=2)$	actual uncertainty declared in CMC $U(k=2)$	uncertainty of the error including stability of the meter $U(k=2)$	key reference value x_{ref}	expanded uncertainty of the key reference value $U(x_{ref})$	d_i	E_i	result
m^3/h	%	%	%	%	%	%	%		
1000	0.08	1.40	-	1.4001	0.168	0.063	-0.09	0.06	passed
800	0.23	1.40	-	1.4001	0.159	0.064	0.07	0.05	passed
650	0.33	1.40	-	1.4001	0.174	0.064	0.16	0.11	passed
450	0.04	1.40	-	1.4001	0.224	0.063	-0.18	0.13	passed
350	0.01	1.40	-	1.4001	0.255	0.063	-0.25	0.18	passed
250	0.30	1.40	-	1.4001	0.280	0.063	0.02	0.01	passed
160	0.72	1.40	-	1.4001	0.335	0.063	0.38	0.28	passed
100	0.13	1.40	-	1.4001	0.328	0.063	-0.20	0.14	passed
50	-0.17	1.40	-	1.4001	0.325	0.063	-0.49	0.35	passed
mean							-0.06	0.15	passed

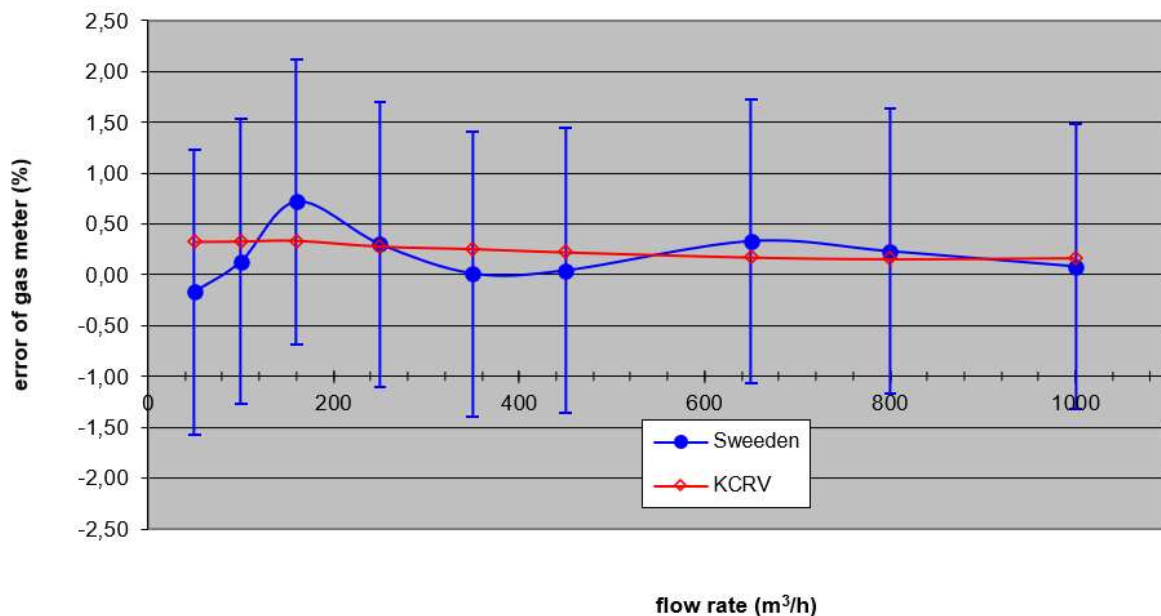

7.9. Switzerland - Independent laboratory

flow rate in the meter	error of the meter in laboratory	uncertainty of the error $U(k=2)$	actual uncertainty declared in CMC $U(k=2)$	uncertainty of the error including stability of the meter $U(k=2)$	key reference value x_{ref}	expanded uncertainty of the key reference value $U(x_{ref})$	di	Ei	result
m ³ /h	%	%	%	%	%	%	%		
1000	0.15	0.16	0.16	0.1609	0.168	0.063	-0.01	0.09	passed
800	0.12	0.16	0.16	0.1609	0.159	0.064	-0.04	0.28	passed
650	0.10	0.16	0.16	0.1609	0.174	0.064	-0.07	0.50	passed
450	0.16	0.16	0.16	0.1609	0.224	0.063	-0.06	0.41	passed
350	0.18	0.16	0.16	0.1609	0.255	0.063	-0.08	0.54	passed
250	0.24	0.16	0.16	0.1609	0.280	0.063	-0.04	0.25	passed
160	0.24	0.16	0.16	0.1609	0.335	0.063	-0.09	0.62	passed
100	0.19	0.16	0.16	0.1609	0.328	0.063	-0.14	0.93	passed
50	0.17	0.16	0.16	0.1609	0.325	0.063	-0.16	1.05	warning
mean							-0.08	0.52	passed

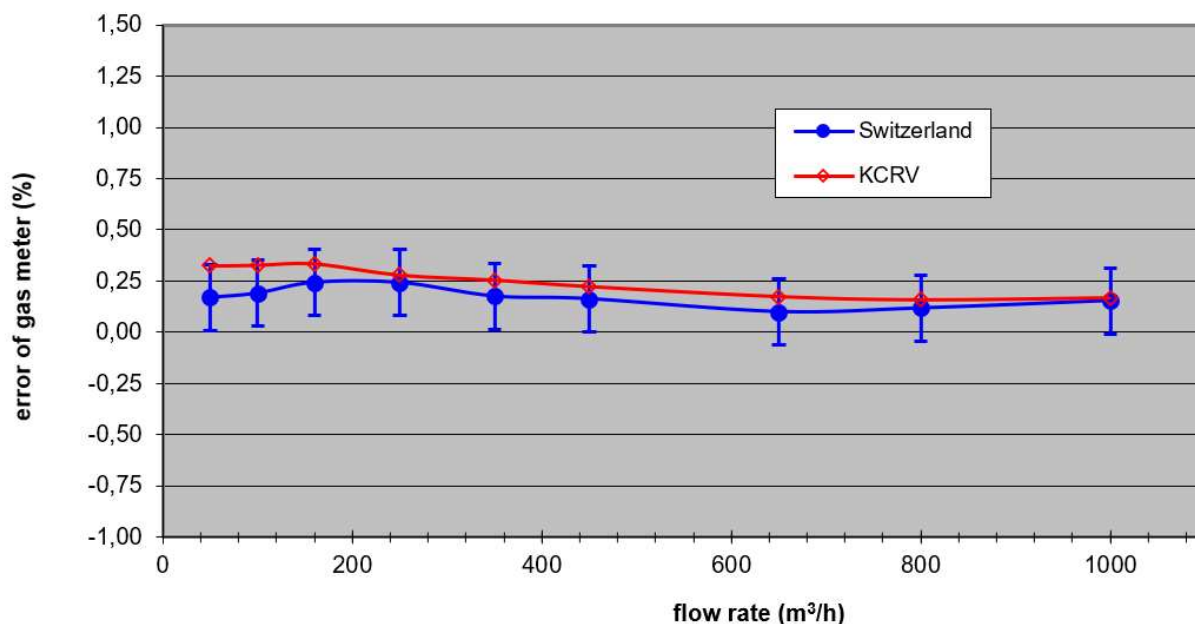

8. Summary and conclusion

The summary of results is mentioned down in the *table 6*. The independent laboratories are **light green**. The laboratories with traceability to Germany (PTB) are **light yellow**. The laboratories with traceability to Netherlands (VSL) are **light blue**. The colour of letters is black if there is evaluation “passed” in tables.

The complete evaluation of each laboratory concerning the key comparison reference value in different flow rates is summarised in the *table 6*.

Table 6 – Evaluation summary of each laboratory from the point of view of key comparison reference values in different flow rates

flow rate (m ³ /h)	Independent Labs					Depending Labs			
	Germany	Netherlands	Poland	Switzerland	Sweden	Austria	Czech Rep.	Denmark	Lithuania
1000	passed	passed	passed	passed	passed	passed	passed	passed	passed
800	passed	passed	passed	passed	passed	passed	passed	passed	passed
650	passed	passed	passed	passed	passed	passed	passed	passed	passed
450	passed	passed	passed	passed	passed	passed	passed	passed	passed
350	passed	passed	passed	passed	passed	passed	passed	passed	passed
250	passed	passed	passed	passed	passed	passed	passed	passed	passed
160	passed	passed	passed	passed	passed	passed	passed	passed	passed
100	passed	passed	passed	passed	passed	passed	passed	passed	passed
50	passed	passed	passed	warning	passed	passed	passed	passed	passed
Mean	passed	passed	passed	passed	passed	passed	passed	passed	passed

The error curves of all participants (*Figure 13*) and of the key comparison reference values are summarised in the graph mentioned down.

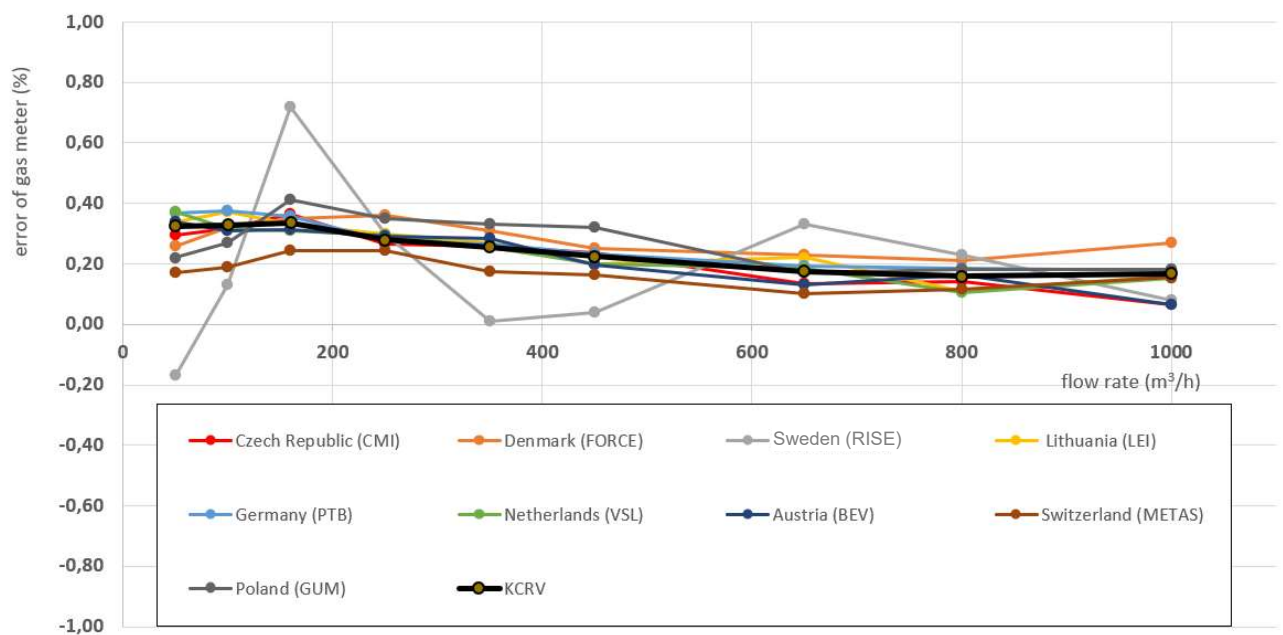

Figure 13 – Error curves of all participants